



# COVIND

*unlimited quality*

Visiere Parasole  
Sun Visors  
Sonnenblende

2021

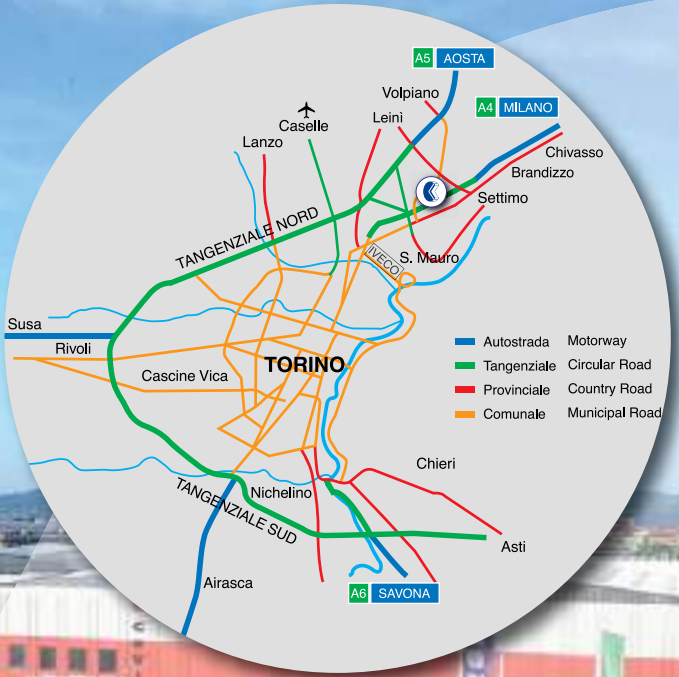



Visiere parasole  
Sun Visors  
Sonnenblende

07.2021





COVIND



كافة التفاصيل المذكوره هنا، وبالرغم من قابليتها للتبديل مع التفاصيل الاصلية بشكل متطابق تماما، إلا انها ليست الأصلية. نفس التفاصيل يتم الاستعانه بها واستخدامها فقط للعربات السائره و فقط بعد الحصول على التصريح بالموافقه من مالك العربيه التي يتم إصلاحها.  
الأرقام الإرشاديه الأصلية يتم وضعها بغرض الاستعلام. نرجو أن يتم دائما ذكر أرقامنا الخاصة الإرشاديه في التعاقبات وطلبات الشراء.  
هذا الكاتالوج بلغي كافة الكاتالوجات السابقه ويحل محلها.



Всички особености изредени по-долу, независимо от това, че са взаимозаменяеми с оригиналите, **не са оригинали**. Те биват използвани само за превозните средства в движение и само след упълномощаване от страна на собственика на превозното средство в ремонт.



Selles nimekirjas olevad varuosad ei ole originaalid vaatamata sellele, **et on originaalidega võrdväärselt kasutatavad**. Neid osasid kasutada ainult töös olevatel sõidukitel ja üksnes remonditava sõiduki omaniku loal. Originaali viitenumbrid on ära toodud ainult infoks. Palume müügi- ja tellimislehtedel ära märkida meie viitenumbrid.  
Käesoleva kataloogi nimekiri tühistab ja asendab varasemad.



Tässä luetteloidut varaosat eivät ole alkuperäisosa, vaikka **ne ovatkin laadultaan alkuperäisosa vastaavia**. Osat on tarkoitettu käytettäväksi liikenteessä olevissa autoissa ja niitä käytetään vain korjattavan ajoneuvon omistajan luvalla. Alkuperäiset tuotekoodit mainitaan vain tiedon vuoksi. Pyydämme teitä käyttämään neuvotteluissa ja tilauslomakkeissa meidän tuotekoodejamme. Uusi tuoteluettelo peruuttaa ja korvaa aikaisemmat luettelot.



Toutes les pièces détaillées ci-dessus, tout en étant parfaitement interchangeables avec les pièces d'origine, **ne sont pas originales**. Les mêmes pièces sont utilisées exclusivement sur les véhicules en circulation et seulement sous autorisation du propriétaire du véhicule en réparation. Les codes de référence originales sont indiqués à titre purement documentaire. Dans les négociations et les commandes veuillez bien citer nos codes de référence. Le présent catalogue annule et remplace tous les précédents.



Alle hier aufgeführten Bestandteile sind exakt austauschbar mit den Originalteilen, **aber es sind keine Originale**. Diese Teile werden nur angewendet und eingesetzt für die Fahrzeuge die im Umlauf sind und nur nach Einverständnis mit dem Eigentümer, dessen Fahrzeug in der Reparatur ist. Die Original-Referenznummern wurden rein informativ nochmals wiedergegeben. Bei Anfragen und bei Bestellungen bitten wir Sie immer die Referenznummern anzugeben. Der beigelegte Katalog ersetzt und annulliert die vorhergehenden Kataloge.



Κάθε ανταλλακτικό που απαριθμείται εδώ, ακόμα κι αν όντας τέλεια ανταλλάξιμο με το γνήσιο, **δεν είναι γνήσιο**. Αυτά τα μέρη χρησιμοποιούνται μόνο στα οχήματα που είναι σε κυκλοφορία και αποκλειστικά μετά από την έγκριση του ιδιοκτήτη του οχήματος για επισκευή. Οι γνήσιοι κωδικοί που αναφέρονται υπάρχουν για πληροφοριακούς λόγους μόνο. Παρακαλούμε όπως χρησιμοποιείτε για οποιαδήποτε συναλλαγή/ παραγγελία σας τους δικούς μας αναφερόμενους κωδικούς. Ο παρών κατάλογος ακυρώνει και αντικαθιστά προηγούμενους.



Spare parts listed here, even though perfectly interchangeable with the original ones, **are not original**. These parts are used only on vehicles in circulation and exclusively under authorization of the owner of the vehicle in repair. The original reference codes are indicated for information only. You are kindly requested to indicate our reference codes in negotiations and order sheets. The present catalogue list cancels and replaces previous ones.



قطعات قید شده در اینجا با اینکه آنها کاملاً قابل تعویض با قطعات اصلی می باشند، قطعات اصلی نیستند. این قطعات تنها برای خودروهایی که در جریان می باشند (خارج از محل تولید می باشند) مورد استفاده قرار می گیرند و منحصرأ تحت اختیار و نضر مالک خودروی در حال تعمیر می باشند. با احترامات ما از شما شماره کد ارجاع اصلی تنها برای اطلاعات می باشند. تقاضا داریم که شماره کد ارجاع را در زمان مذاکره و در ورقه تقاضا مشخص کنید. لیست



Tutti i particolari qui elencati, pur essendo perfettamente intercambiabili con gli originali, **non sono originali**. Gli stessi vengono impiegati ed utilizzati solo per i veicoli in circolazione e solo dopo autorizzazione da parte del proprietario del veicolo in riparazione. I numeri di riferimento originali sono riportati a puro titolo informativo. Nelle trattative e nelle ordinazioni si prega di voler sempre citare i nostri numeri di riferimento. Il presente catalogo annulla e sostituisce tutti i precedenti.



Kaut arī uzskaitītās rezerves daļas var pilnīgi aizstāt oriģinālās, **tās nav oriģinālas**. Šīs rezerves daļas tiek izmantotas vienīgi apgrozībā esošiem transporta līdzekļiem un tikai ar remontējamā transporta līdzekļa īpašnieka atļauju. Oriģinālais atsauces numurs tiek uzrādīts vienīgi informācijai. Lūdzam norādīt jūsu atsauces numurus sarunu laikā un uz pasūtījuma lapas. Šis kataloga saraksts anulē un aizstāj visus iepriekšējos.



Čia išvardytos atsarginės dalys nėra originalios, tačiau jomis galima pakeisti originaliąsias. Šios dalys naudojamos tik apyvartoje esančiuose automobiliuose ir tik gavus remontuojamo automobilio savininko sutikimą.

Originalių dalių kodai nurodomi tik informacijos sumetimais. Maloniai prašome nusiskundimuose ir užsakymų lapuose nurodyti dalių kodus.

Šiame kataloge pateikiamas sąrašas anuliuoja ir pakeičia ankstesnius.



Reservedelene som er oppført her, er ikke **originale reservedeler**, selv om de fullt ut kan benyttes ved utskiftning av de opprinnelige delene. De skal kun benyttes på kjøretøy som er i bruk og med eierens samtykke. De opprinnelige referansekodene angis kun til etterretning. Vennligst angi våre referansekoder under forhandling og ved bestilling. Denne katalogen annullerer og erstatter alle tidligere kataloger.



Hoewel elk reserveonderdeel dat hier vermeld wordt perfekt kan worden gebruikt in de plaats van de originele stukken, **gaat het hier dus niet om originele onderdelen**. Deze onderdelen worden enkel gebruikt voor voertuigen in circulatie en enkel met de toestemming van de eigenaar van het voertuig dat in reparatie is. De originele referentiecodes worden enkel ter informatie weergegeven. U wordt vriendelijk verzocht om onze referentiecodes te gebruiken in gesprekken en op de bestelformulieren. De huidige catalogoog annuleert en vervangt de vorige versies.



Wszystkie detale tu podane ,choć będąc doskonałe wymienne z oryginałami, **nie są oryginalne**. Te same zostają zastosowane i użyte tylko dla pojazdów w obiegu i tylko po autoryzacji ze strony właściciela pojazdu będącego w naprawie.

Oryginalne numery referencyjne są umieszczone w celu czysto informacyjnym.

W czasie rozmów handlowych i zamówień, prosi się zechcieć zawsze cytować nasze numery referencyjne.

Niniejszy katalog anuluje i zastępuje wszystkie poprzednie.



Todas as peças aqui listadas, ainda que sejam perfeitamente intercambiáveis com as originais, **não são originais**. Estas peças só são empregues e utilizadas nos veículos em circulação e só após autorização prévia por parte do proprietário do veículo a reparar. Os números de referência originais têm um carácter puramente informativo. Nos contactos e encomendas, indique sempre os números de referência, por favor.



Veškeré zde uvedené součástky **nejsou originální díly**, i když jsou za ně stoprocentně zaměnitelné. Tyto součástky je možné použít pouze pro vozidla v provozu a pouze se souhlasem majitele vozidla, které má být opraveno. Referenční čísla originálních dílů jsou uvedena pouze informativně. Při jednáních a na objednávkách je nutné vždy uvést naše referenční čísla.

Tento katalog anuluje a nahrazuje veškeré předchozí katalogy.



Toate produsele enumerate in continuare, chiar daca sunt perfect interschimbabile cu cele originale, **nu sunt originale**. Ele sunt utilizate, numai pentru autovehiculele in circulatie si exclusiv cu acordul proprietarului autovehiculului de reparat. Codurile originale sunt indicate numai in scop informativ. Cu ocazia tratativelor verbale, cat si a emiterii ordinelor scrise, clientii sunt rugati sa utilizeze codurile noastre (COVIND) ca referinta. Prezentul catalog anuleaza si le inlocuieste pe cele precedente.



Все перечисленные запчасти не являются оригинальными, **хотя могут отлично их заменить**. Эти запчасти используются при ремонте автомобилей только с согласия владельца.

Ссылки на порядковый номер оригинальных запчастей указаны исключительно в ориентировочных целях.

При покупках и заказах рекомендуем указывать НАШИ номера запчастей.

Настоящий каталог анулирует и заменяет все предыдущие.

Оригинальные ориентировочные номера са изнесени само за ваша информация. При преговори и при поръчки молим винаги да цитирате нашите ориентировочни номера.

Настоящият каталог анулира и замества всички съществуващи до момента.



Ovdje popisani prièuvni dijelovi, èak i kada savršeno zamjenjuju izvorne, **nisu izvorni**. Ti dijelovi mogu se uporabiti jedino na vozilima u cirkulaciji i na temelju izrièitoga odobrenja vlasnika vozila na popravku. Brojevi dijela izvornih dijelova navedeni su samo kao primjer. Najljepše vas molimo da u vašim zahtjevima i narudžbama navedete brojeve dijela.

Sadašnji katalog ukida valjanost svih prethodnih kataloga.



Èeprav jih je možno perfektno izmenjati z originalnimi deli, tukaj navedeni nadomestni deli niso originalni. Te dele se uporabljajo samo v vozilih v prometu in izkljuèno samo pod pogojem, da lastnika vozila v popravilu izda zato dovoljenje. Navedene originalne referenène kode so le informativne. Prosimo vas, da navedite naše referenène kode pri pogajanju in na naroèilih. S sedanjim seznamom prenehajo veljati prejšnji sezname in jih nadomesti.



Todos los elementos detallados a continuación, aunque totalmente intercambiables con los originales, **no son originales**. Estos mismos se emplean y utilizan unicamente para vehículos en circulación y previa autorización del propietario del vehículo en reparación. Los numeros de referencia originales se citan a título informativo. En las negociaciones y en los pedidos se ruega citar siempre nuestros numeros de referencia. El presente catálogo anula y substituye todos los anteriores.



Reservdelarna i denna lista är inte originaldelar trots att de **är fullkomligt utbytbara med de ursprungliga**. Dessa delar används endast på fordon i cirkulation och enbart efter godkännande av ägaren till det fordon som lämnats på reparation. De originala referenskoderna anges endast för information. Var god ange våra referenskoder i negocieringar och beställningsblanketter. Den nuvarande kataloglistan annullerar och ersätter de föregående.



Devamında detaylandırılan tüm elementler, orijinaleri ile tamamen değiştirilebilir olmasına rağmen, **orijinal değildirler**. Bunlar, yalnızca dolaşımda bulunan araçlarda ve tamirde bulunan aracın sahibinden ön onay alınması kaydıyla uygulanabilir ve kullanılabilir.

Orijinallerin referans numaraları bilgi başlığında yer almaktadır.

Görüşmelerde ve siparişlerde referans numaralarımızın her zaman belirtilmesi rica olunur.

Bu katalog tüm önceki versiyonları geçersiz kılar ve bunların yerine geçer.



Перелічені тут запасні частини не є оригінальними, але цілком взаємозамінні з оригінальними. Ці запасні частини застосовуються тільки на транспортних засобах, що знаходяться в експлуатації і винятково з дозволу власника, що здав транспортний засіб у ремонт.

Коди оригінальних запасних частин наводяться тільки для довідки. Прохання вказувати довідкові коди запасних частин при веденні переговорів і на бланках замовлення.

Даний каталог скасовує дію раніше виданих каталогів і замінює ці каталоги.



Az itt felsorolt tartalék alkatrészek, még akkor is, ha megfelelően felcserélhetők az eredetiekkel, nem az eredetiek. Ezeket az alkatrészeket csak forgalomban lévő járművek javításánál használják és kizárólag a jármű tulajdonosának engedélyével.

Az eredeti referencia kódokat csak információs célból jelzik. Kérjük legyen szíves jelezze a referencia kódjainkat a tárgyalásokon és a megrendelési dokumentumban.

A jelenlegi katalógus lista vissza van vonva és újra az előző lista van érvényben.

# WWW.COVIND.IT

Si consiglia di consultare sempre il catalogo on-line per gli ultimi aggiornamenti.

Please visit the catalogue on-line for the latest updates.

Il est conseillé de toujours consulter le catalogue en ligne pour les dernières mises à jour.

Wir empfehlen Ihnen immer unsere on line Kataloge nachzuschlagen, um die letzten Aktualisierungen zu kennen

Les recomendamos consulten siempre el catálogo en línea para las últimas actualizaciones.

Recomenda-se a consulta do catálogo eletrônico para informação das novas atualizações.

Zaleca się odwiedzać zawsze katalog on-line zawierający najnowsze aktualizacje

E consiliabila intotdeauna, consultarea catalogului on-line pentru cunoasterea ultimilor actualizari.

Пожалуйста, обратите внимание на последние обновления каталогов on-line

للأطلاع على آخر التحديثات،  
الرجاء الرجور دائما الى كاتالوجاتنا على الخط.



# Index \_ legenda

## TABELLE COMPARATIVE CROSS REFERENCE KORRESPONDENZTABELLE

OEMCOVIND	.INTRO 12
COVIND-OEM	.INTRO 16

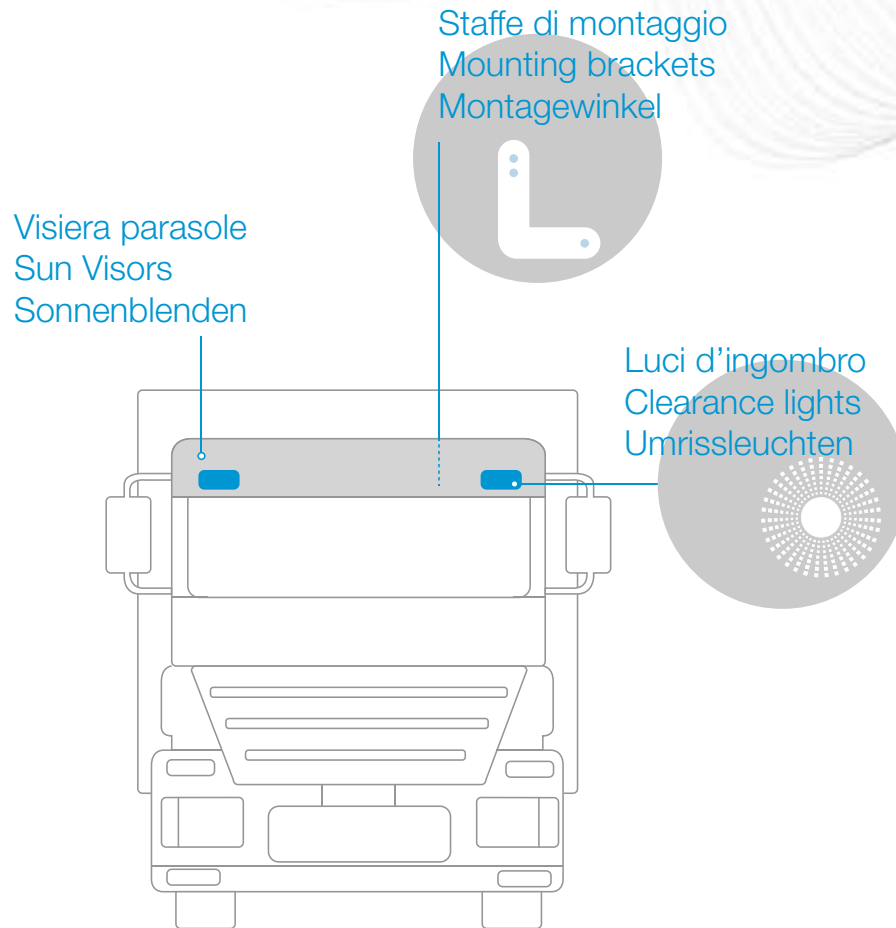

## INDEX

DAF	.01
IVECO	.09
MAN	.21
MERCEDES-BENZ	.31
RENAULT	.63
SCANIA	.69
VOLVO	.73

## LEGENDA

	Luci d'ingombro Clearance lights Umrissleuchten
	Staffe di montaggio (con minuterie) Mounting brackets (with small parts) Montagewinkel (mit Kleinteilen)
	Kit di montaggio Assembly kit Aufbausatz
	Elemento di copertura della visiera parasole Cover element of the sun visor Abdeckelement der Sonnenblende
	Connettore ovale Oval connector Ovaler Verbinder
	Connettore rettangolare Rectangular connector Rechteckiger Verbinder

# EXPOSUNVISORS

## VISIERE COVIND: FA CHE LA TUA VISTA CONTI!

Contattate il nostro ufficio commerciale per scoprire come avere il vostro espositore personalizzato.

## COVIND EXPOSUNVISORS: MAKE VISION COUNT!

Contact our sales department to find out how to have your expomirror customized.

## COVIND SONNENBELNDEN: DEINE SICHT IST UNS WICHTIG!

Kontaktieren Sie unseren Verkauf Abteilung, um Ihren personalisierten Expomirror zu bekommen

---



gallery

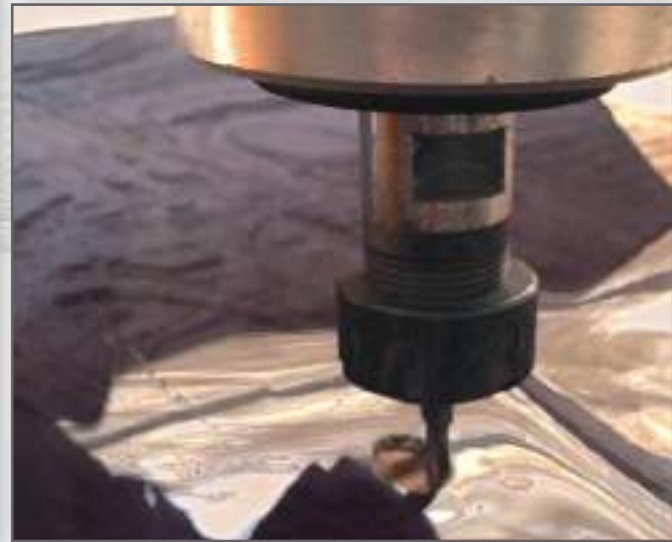

COVIND

Cod. Originale	Cod. Covind	Pag.Cat.
O.E.M. Ref.	Covind Ref.	Page Cat.
OE Nummer	Covind Teilnummer	Seite
<b>DAF</b>		
1300557	XF0/405	5
1311766	XF0/480	5
1312864	CF0/400	1
1312868	CF0/400	1
1312872	CF0/480	1
1371875	CF0/410	3
1434304	CF0/480	1
1434334	CF0/485	3
1651597	XF0/425	6
1785061	CF0/405	2
<b>IVECO</b>		
2995676	240/400	14
93162831	240/400	14
500314716	240/417	14,16
500314717	240/416	14,16
500337805	530/400	12
500338393	440/405	16
504027710	530/400	12
504029359	550/400	10
504042824	540/400	13
504047264	540/417	12,13,15
504047265	540/416	12,13,15
504061726	075/400	* 9
504061726	075/485	* 9
504067744	075/400	* 9
504067744	075/480	* 9
504074031	075/416	9,10,11,12
504074032	075/417	9,10,11,12

Cod. Originale	Cod. Covind	Pag.Cat.
O.E.M. Ref.	Covind Ref.	Page Cat.
OE Nummer	Covind Teilnummer	Seite
504080328	540/400	13
504089358	550/400	10
504089372	550/400	10
504107220	530/400	12
504107239	440/400	15
504146434	560/400	11
504146530	560/400	11
5801715565	580/400	17
5801715566	580/405	18
-	075/415	9,10,11,12
-	240/415	14,16
-	240/480	14
-	440/480	15,16
-	530/480	12
-	540/415	12,13,15
-	540/480	13
-	550/480	10
-	560/480	11
<b>MAN</b>		
81637010010	F90/400	28
81637010021	M20/400	29
81637010024	L20/480	27
81637010031	XXL/415	26
81637010033	TGX/400	23
81637010044	TGX/400	23
81637010046	XXL/415	26
81637010047	MLX/405	22
81637010048	XXL/405	24
81637010055	TGL/400	21

Cod. Originale	Cod. Covind	Pag.Cat.
O.E.M. Ref.	Covind Ref.	Page Cat.
OE Nummer	Covind Teilnummer	Seite
81637010057	XXL/410	25
81637010058	TGL/400	21
81637010060	MLX/405	22
81637010062	XXL/405	24
81637310282	TGX/480	23
81637310283	XXL/490	25,26
81637350024	M20/480	28,29
81637350028	XXL/490	25,26
81637350029	TGX/480	23
81637350032	MLX/480	21,22,24
81991828761	F90/400	28
81991828764	M20/400	29
85637010010	L20/480	27
-	M20/485	28,29
<b>MERCEDES-BENZ</b>		
0028100514	940/485	36
0028100614	973/490	32
0028101714	973/485	33
3818111014	641/480	58
3818112510	381/400	60
3818112710	641/400	58
3898110010	649/480	59
6738110010	670/400	34
6738110814	670/480	34
9418100010	941/410	56
9418100714	941/485	57
9418101010	941/415	57
9418101114	941/480	56
9418110010	941/405	55

<b>Cod. Originale</b> O.E.M. Ref. OE Nummer	<b>Cod. Covind</b> Covind Ref. Covind Teilnummer	<b>Pag.Cat.</b> Page Cat. Seite
9418110610	941/405	55
9418110810	941/400	54
9438100410	943/425	51
9438100610	943/420	50
9438100810	943/430	52
9438100814	943/485	46,48,49
9438100910	943/435	53
9438100914	943/490	47
9438101614	943/480	51,52
9438101714	943/495	50
9438110010	943/410	48
9438110210	943/405	47
9438111010	943/415	49
9438111210	943/400	46
9608102310	960/420	42
9608102610	960/410	40
9608102910	960/425	43
9608103210	960/435	45
9608104610	960/410	40
9608104810	960/420	42
9608105210	960/425	43
9608105510	960/435	45
9608110010	960/405	39
9608110110	960/400	38
9608110610	960/415	41
9608111210	960/430	44
9608112210	960/405	39
9608112310	960/400	38
9608112410	960/415	41

<b>Cod. Originale</b> O.E.M. Ref. OE Nummer	<b>Cod. Covind</b> Covind Ref. Covind Teilnummer	<b>Pag.Cat.</b> Page Cat. Seite
9608113010	960/430	44
9738100014	940/480	35
9738101514	973/480	31
9738110310	940/400	35
9738110410	973/400	31
9738110510	940/405	36
9738110610	973/405	32
9738110710	973/405	32
9738110810	940/410	37
9738111010	973/410	33
-	381/480	60
-	940/490	37
<b>RENAULT</b>		
5010578255	PRM/405	64
5010578255	PRM/410	65
5010578256	PRM/415	64,65
7420819179	385/480	66,74
7420937410	MDL/400	63
7420937418	385/400	66
7420937430	MDL/400	63
7420937442	385/400	66
7482644956	PRM/415	64,65
-	PRM/420	64,65
<b>SCANIA</b>		
2312092	146/400	70
2055596	146/400	70
2312064	146/405	71
2055591	146/405	71
2117867	146/405	71

<b>Cod. Originale</b> O.E.M. Ref. OE Nummer	<b>Cod. Covind</b> Covind Ref. Covind Teilnummer	<b>Pag.Cat.</b> Page Cat. Seite
2312065	146/410	71
2055592	146/410	71
2117868	146/410	71
2312066	146/415	71
2055593	146/415	71
2117869	146/415	71
2312077	146/420	71
2055594	146/420	71
2117870	146/420	71
2541737	R50/400	69
2341420	R50/400	69
2341421	R50/405	69
2341423	R50/405	69
<b>VOLVO</b>		
8140923	0FH/400	76
8189318	0FH/400	76
20456709	2FH/400	75
20467412	2FH/480	75
20467414	2FH/480	75
20467422	2FH/480	75
20467424	2FH/480	75
20501225	0FE/400	73
20527443	2FH/410	75
20743944	0FL/400	74
20819179	385/480	66,74
20937431	0FE/400	73
20937442	0FL/400	74

gallery



COVERING

gallery



COVIND

Cod. Covind Covind Ref. Covind Teilnummer	Cod. Originale O.E.M. Ref. OE Nummer	Pag.Cat. Page Cat. Seite
<b>DAF</b>		
CF0/400	1312864	1
CF0/400	1312868	1
CF0/405	1785061	2
CF0/410	1371875	3
CF0/480	1434304	1
CF0/480	1312872	1
CF0/485	1434334	3
XF0/400	1286384	4
XF0/405	1300557	5
XF0/425	1651597	6
XF0/480	1311766	5
<b>IVECO</b>		
075/400	504067744 *	9
075/400	504061726 *	9
075/415	-	9,10,11,12
075/416	504074031	9,10,11,12
075/417	504074032	9,10,11,12
075/480	504067744 *	9
075/485	504061726 *	9
240/400	2995676	14
240/400	93162831	14
240/415	-	14,16
240/416	500314717	14,16
240/417	500314716	14,16
240/480	-	14
440/400	504107239	15
440/405	500338393	16
440/480	-	15,16

Cod. Covind Covind Ref. Covind Teilnummer	Cod. Originale O.E.M. Ref. OE Nummer	Pag.Cat. Page Cat. Seite
530/400	504107220	12
530/400	500337805	12
530/400	504027710	12
530/480	-	12
540/400	504042824	13
540/400	504080328	13
540/415	-	12,13,15
540/416	504047265	12,13,15
540/417	504047264	12,13,15
540/480	-	13
550/400	504089372	10
550/400	504029359	10
550/400	504089358	10
550/480	-	10
560/400	504146530	11
560/400	504146434	11
560/480	-	11
580/400	5801715565	17
580/405	5801715566	18
<b>MAN</b>		
F90/400	81637010010	28
F90/400	81991828761	28
L20/480	85637010010	27
L20/480	81637010024	27
M20/400	81637010021	29
M20/400	81991828764	29
M20/480	81637350024	28,29
M20/485	-	28,29
MLX/405	81637010060	22

Cod. Covind Covind Ref. Covind Teilnummer	Cod. Originale O.E.M. Ref. OE Nummer	Pag.Cat. Page Cat. Seite
MLX/405	81637010047	22
MLX/480	81637350032	21,22,24
TGL/400	81637010055	21
TGL/400	81637010058	21
TGX/400	81637010044	23
TGX/400	81637010033	23
TGX/480	81637350029	23
TGX/480	81637310282	23
XXL/405	81637010062	24
XXL/405	81637010048	24
XXL/410	81637010057	25
XXL/415	81637010046	26
XXL/415	81637010031	26
XXL/490	81637350028	25,26
XXL/490	81637310283	25,26
<b>MERCEDES-BENZ</b>		
381/400	3818112510	60
381/480	-	60
641/400	3818112710	58
641/480	3818111014	58
649/480	3898110010	59
670/400	6738110010	34
670/480	6738110814	34
940/400	9738110310	35
940/405	9738110510	36
940/410	9738110810	37
940/480	9738100014	35
940/485	0028100514	36
940/490	-	37

<b>Cod. Covind</b> Covind Ref. Covind Teilnummer	<b>Cod. Originale</b> O.E.M. Ref. OE Nummer	<b>Pag.Cat.</b> Page Cat. Seite
941/400	9418110810	54
941/405	9418110610	55
941/405	9418110010	55
941/410	9418100010	56
941/415	9418101010	57
941/480	9418101114	56
941/485	9418100714	57
943/400	9438111210	46
943/405	9438110210	47
943/410	9438110010	48
943/415	9438111010	49
943/420	9438100610	50
943/425	9438100410	51
943/430	9438100810	52
943/435	9438100910	53
943/480	9438101614	51,52
943/485	9438100814	46,48,49
943/490	9438100914	47
943/495	9438101714	50
960/400	9608112310	38
960/400	9608110110	38
960/405	9608112210	39
960/405	9608110010	39
960/410	9608104610	40
960/410	9608102610	40
960/415	9608112410	41
960/415	9608110610	41
960/420	9608104810	42
960/420	9608102310	42

<b>Cod. Covind</b> Covind Ref. Covind Teilnummer	<b>Cod. Originale</b> O.E.M. Ref. OE Nummer	<b>Pag.Cat.</b> Page Cat. Seite
960/425	9608105210	43
960/425	9608102910	43
960/430	9608113010	44
960/430	9608111210	44
960/435	9608105510	45
960/435	9608103210	45
973/400	9738110410	31
973/405	9738110610	32
973/405	9738110710	32
973/410	9738111010	33
973/480	9738101514	31
973/485	0028101714	33
973/490	0028100614	32
<b>RENAULT</b>		
385/400	7420937418	66
385/400	7420937442	66
385/480	7420819179	66,74
MDL/400	7420937410	63
MDL/400	7420937430	63
PRM/405	5010578255	64
PRM/410	5010578255	65
PRM/415	7482644956	64,65
PRM/415	5010578256	64,65
PRM/420	-	64,6
<b>SCANIA</b>		
146/400	2312092	70
146/400	2055596	70
146/405	2312064	71
146/405	2055591	71

<b>Cod. Covind</b> Covind Ref. Covind Teilnummer	<b>Cod. Originale</b> O.E.M. Ref. OE Nummer	<b>Pag.Cat.</b> Page Cat. Seite
146/405	2117867	71
146/410	2312065	71
146/410	2055592	71
146/410	2117868	71
146/415	2312066	71
146/415	2055593	71
146/415	2117869	71
146/420	2312077	71
146/420	2055594	71
146/420	2117870	71
R50/400	2541737	69
R50/400	2341420	69
R50/405	2341421	69
R50/405	2341423	69
<b>VOLVO</b>		
0FE/400	20937431	73
0FE/400	20501225	73
0FH/400	8189318	76
0FH/400	8140923	76
0FL/400	20937442	74
0FL/400	20743944	74
2FH/400	20456709	75
2FH/410	20527443	75
2FH/480	20467422	75
2FH/480	20467412	75
2FH/480	20467414	75
2FH/480	20467424	75
385/480	20819179	66,74

gallery



COVIND

**CF0/400** 1312864  
1312868

materiale | material | material PMMA - Acrylglas

peso | weight | Gewicht 3,505 Kg

applicabilità | suitable to | für DAF CF65 Comfort Cab  
DAF CF75 Comfort Cab  
DAF CF85 Comfort Cab  
DAF CF euro 6



DAF

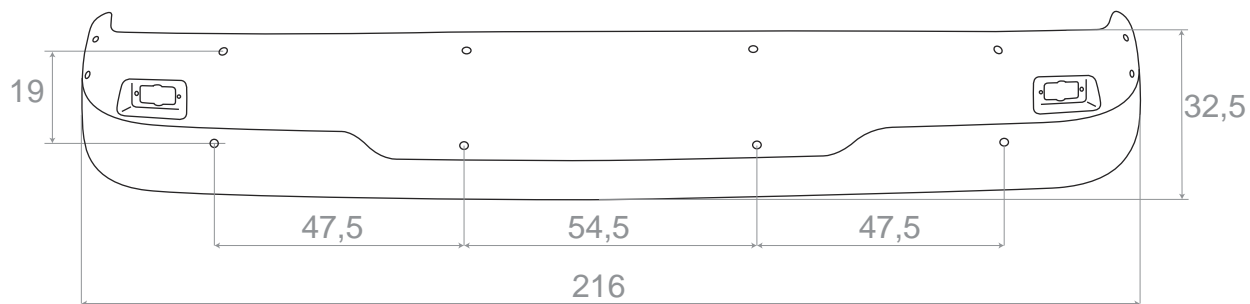

(cm)

extra



**CF0/480** 1434304  
1312872



COVERED

**CF0/405** 1785061

materiale | material | material PMMA - Acrylglas

peso | weight | Gewicht 3,905 Kg

applicabilità | suitable to | für  
 DAF CF space cab  
 tetto alto | high roof | hohes Dach  
 DAF CF 65 space cab  
 DAF CF 75 space cab  
 DAF CF 85 space cab  
 DAF CF euro 6 space cab

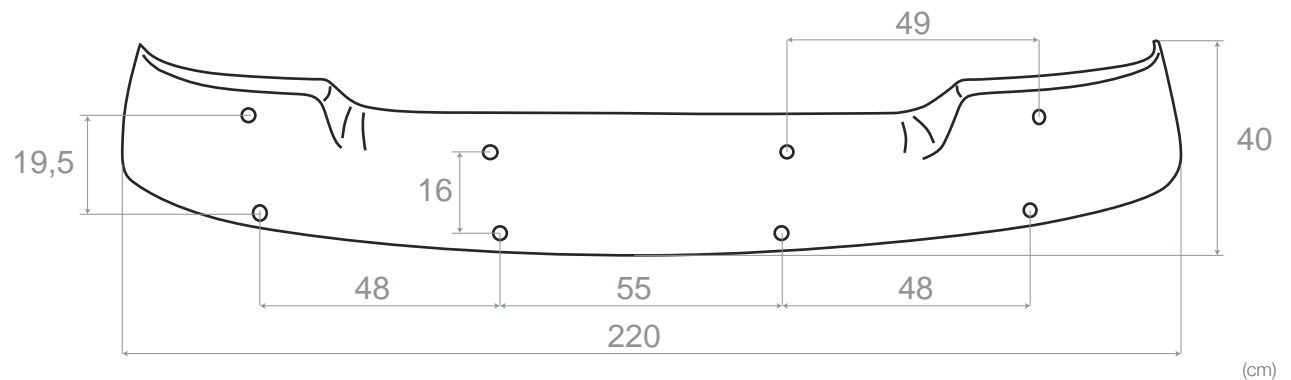

extra



**COVIND**

**CF0/410** 1371875

materiale | material | material Polimetilmetacrilato

peso | weight | Gewicht 4,055 Kg

applicabilità | suitable to | für DAF CF 65  
DAF CF 75  
DAF CF 85

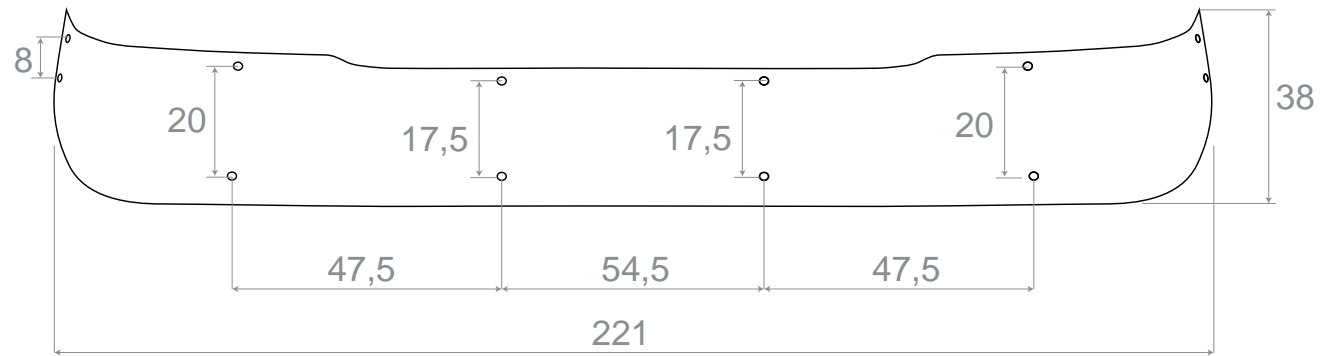

(cm)



**CF0/485** 1434334



**XF0/400** 1286384

materiale | material | material PMMA - Acrylglas

peso | weight | Gewicht 1,870 Kg

applicabilità | suitable to | für DAF 95XF  
DAF XF95  
tetto alto | high roof | hohes Dach



extra



COVIND

**XF0/405** 1300557

materiale | material | material PMMA - Acrylglas

peso | weight | Gewicht 3,60 Kg

applicabilità | suitable to | für DAF 95XF space cab  
 DAF XF95 space cab  
 DAF XF105 space cab  
 tetto medio | medium roof | mittelhohes dach  
 DAF XF106 euro 6  
 DAF XF106 euro 6 Restyling

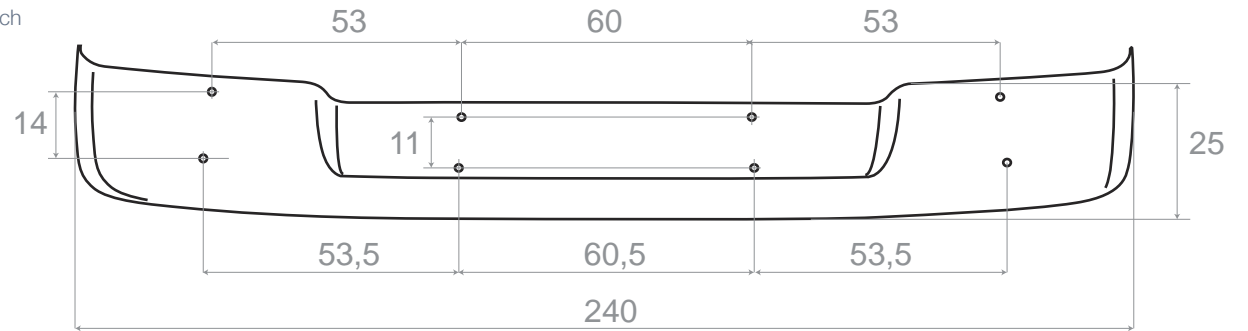

(cm)



**XF0/480** 1311766

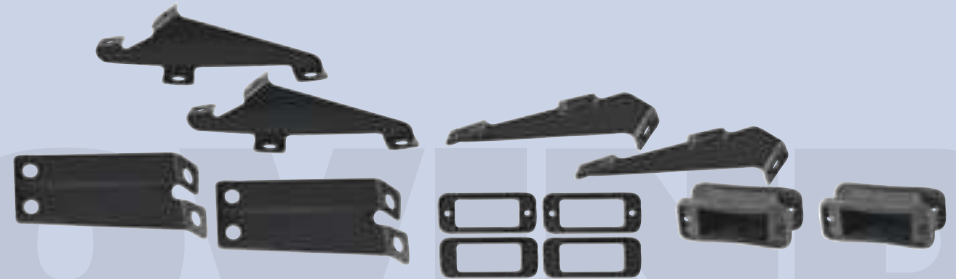

**XF0/425** 1651597

materiale | material | material PMMA - Acrylglas

peso | weight | Gewicht 2,305 Kg

applicabilità | suitable to | für  
DAF 95XF  
DAF XF95  
DAF XF105 super space cab  
DAF XF106 euro 6  
DAF XF106 euro 6 Restyling  
DAF CF euro 6

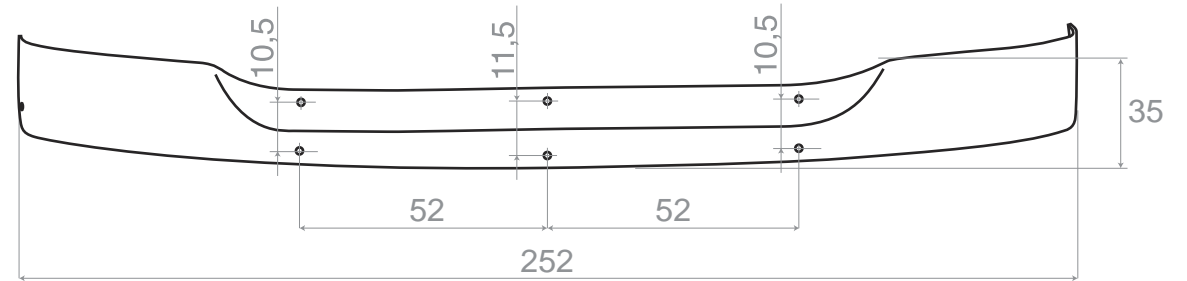

(cm)

extra



**COVIND**

gallery



COVIND

gallery

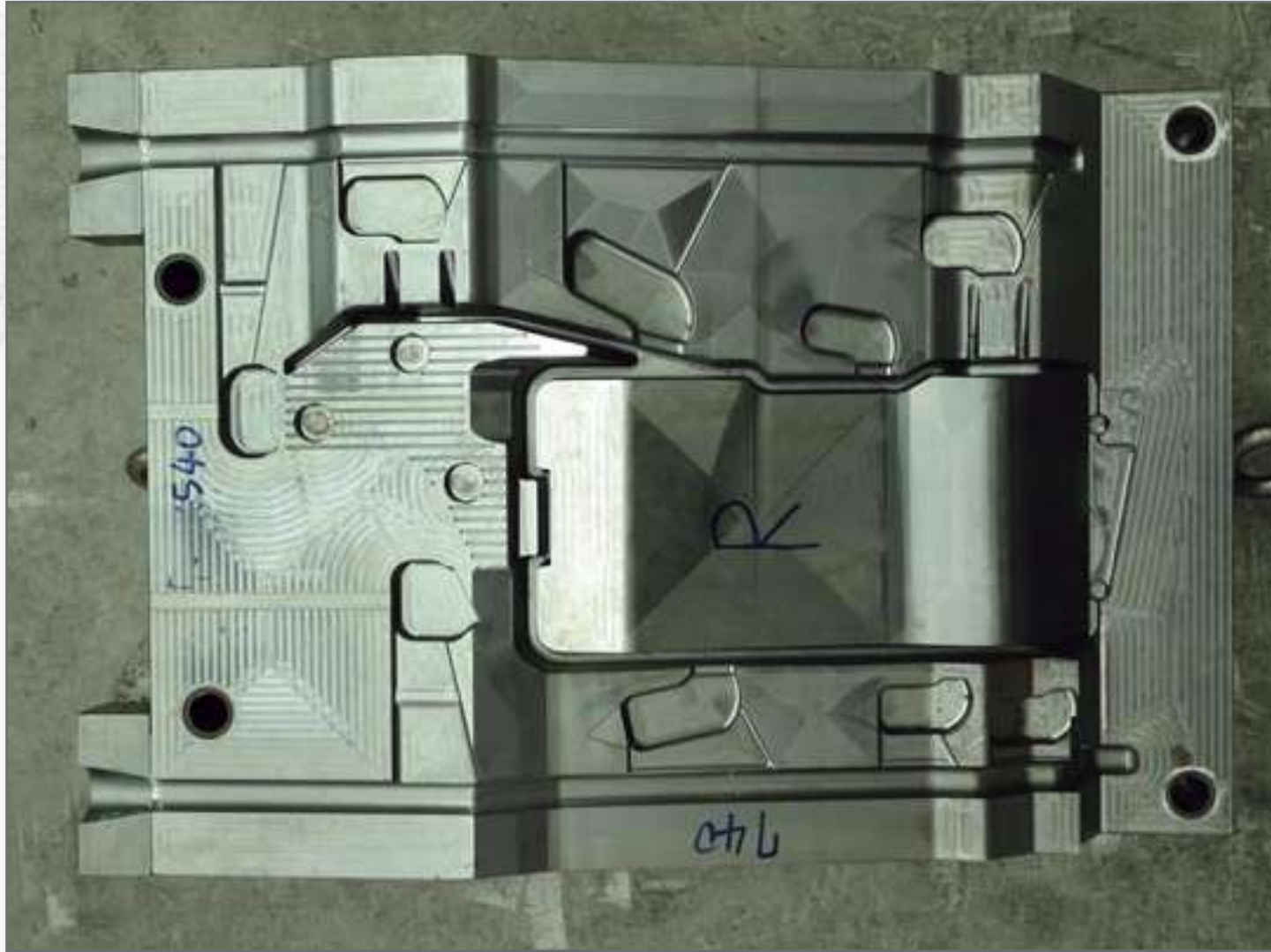

COVIND

**075/400**

504067744\* tetto alto | high roof | hohes Dach  
 504061726\* tetto basso | low roof | niedriges Dach

materiale | material | material PMMA - Acrylglas

peso | weight | Gewicht 4,045 Kg

applicabilità | suitable to | für IVECO Tector restyling  
 IVECO Tector restyling  
 IVECO Tector restyling  
 IVECO Eurocargo 2008  
 IVECO Eurocargo 2008

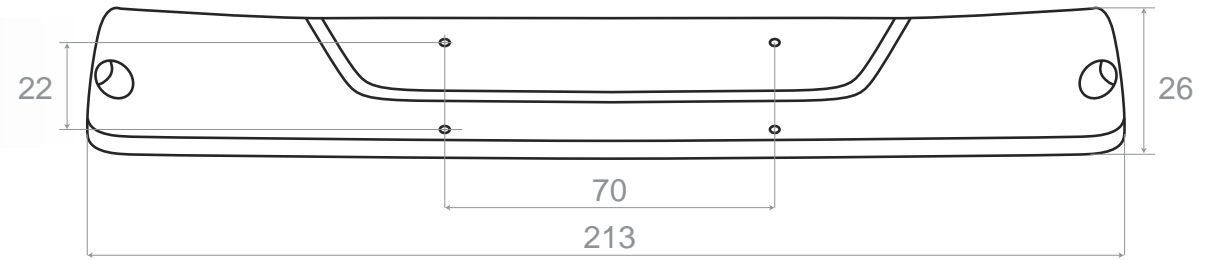

(cm)

- \* L'OEM fornisce kit completo (visiera+luce+staffe). COVIND fornisce singolarmente ogni elemento
- \* OEM supplies the complete kit (sun visor+lights+brackets). COVIND supplies each single item
- \* OEM liefert den kompletten Satz (Sonnenblende+Lichte+Bügel). COVIND liefert jedes Einzelteil

# extra



**075/415**

**KIT** (075/416+075/417)

**075/416**

d-rh-rechts

504074031

**075/417**

s-lh-links

504074032



**075/480**

504067744

tetto alto | high roof | hohes Dach



**075/485**

504061726

tetto basso | low roof | niedriges Dach

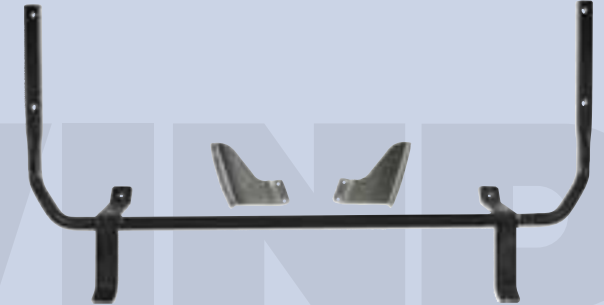
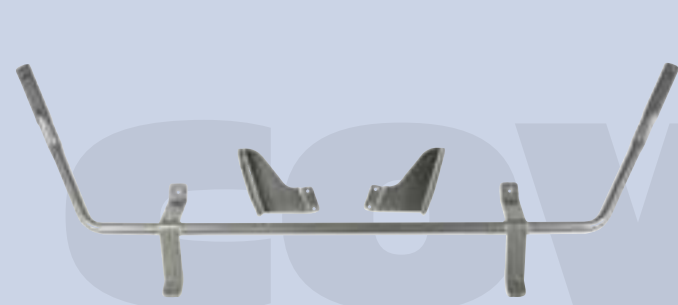

**550/400**

504089372  
504089358  
504029359

materiale | material | material PMMA - Acrylglas

peso | weight | Gewicht 5,640 Kg

applicabilità | suitable to | für IVECO AD/AT Stralis 2007  
IVECO AD/AT Stralis  
IVECO AD/AT Trakker 2007  
IVECO AD/AT Trakker (E4)  
IVECO AD/AT Stralis 2013

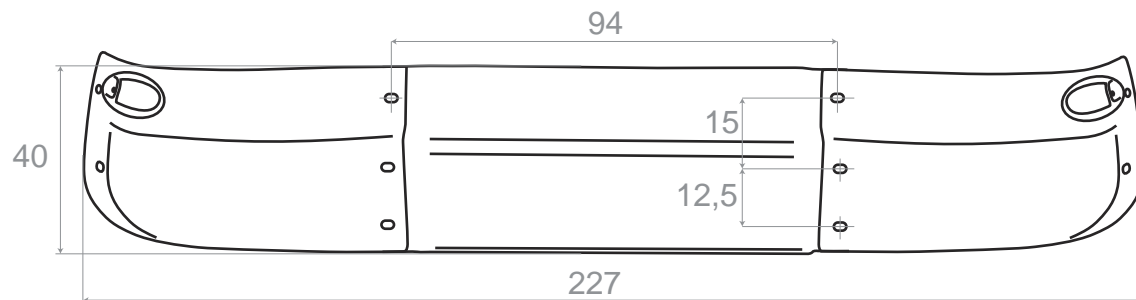

(cm)

extra



**075/415**

**KIT** (075/416+075/417)

**075/416**

d-rh-rechts

504074031

**075/417**

s-lh-links

504074032



**550/480**



COVERING

**560/400** 504146530  
504146434

materiale | material | material PMMA - Acrylglas

peso | weight /Gewicht 4,185 Kg

applicabilità | suitable to | für IVECO AS Stralis 2007

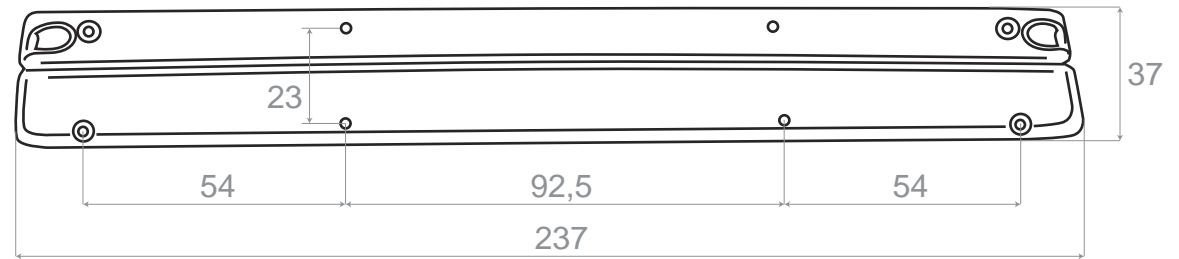

(cm)

extra



**075/415** -  
**KIT** (075/416+075/417)

**075/416** 504074031  
d-rh-rechts

**075/417** 504074032  
s-lh-links



**560/480** -



**530/400**

504107220  
504027710  
500337805

materiale | material | material PMMA - Acrylglas

peso | weight | Gewicht 2,725 Kg

applicabilità | suitable to | für IVECO AD/AT Stralis 2007  
IVECO AD/AT Trakker 2007  
IVECO AD/AT Trakker (E4)  
IVECO AD/AT Stralis  
IVECO AD/AT Stralis 2013  
IVECO Eurotech  
IVECO Eutotrakker

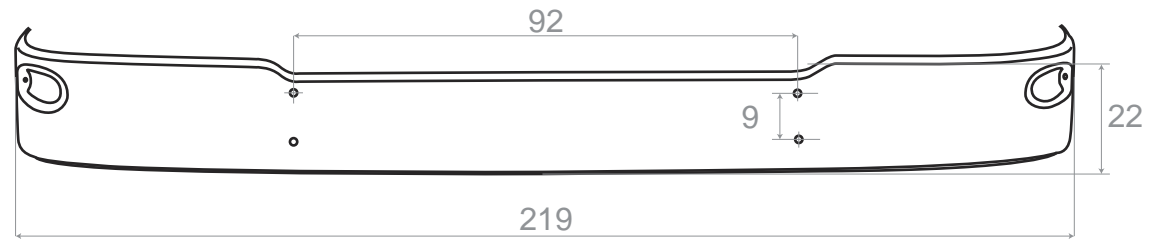

(cm)

extra



**075/415**

**KIT** (075/416+075/417)

**075/416**

d-rh-rechts

504074031

**075/417**

s-lh-links

504074032



**540/415**

**KIT** (540/416+540/417)

**540/416**

d-rh-rechts

504047265

**540/417**

s-lh-links

504047264



**530/480**



**540/400**

504042824  
504080328

materiale | material | material PMMA - Acrylglas

peso | weight | Gewicht 6,275

applicabilità | suitable to | für IVECO AS Stralis



IVECO

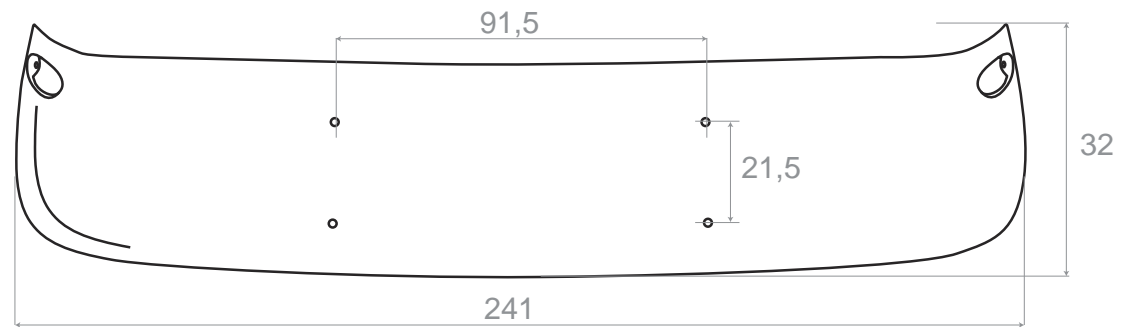

(cm)

extra



**540/415**

**KIT** (540/416+540/417)

**540/416**

d-rh-rechts

504047265

**540/417**

s-lh-links

504047264



**540/480**

-



COVINT

**240/400**

2995676  
93162831

materiale | material | material PMMA - Acrylglas

peso | weight | Gewicht 2,815 Kg

applicabilità | suitable to | für IVECO Eurotech  
IVECO Eurotrakker

tetto basso | low roof | niedriges Dach

tetto medio | medium roof | mittelhohes Dach

tetto alto | high roof | hohes Dach

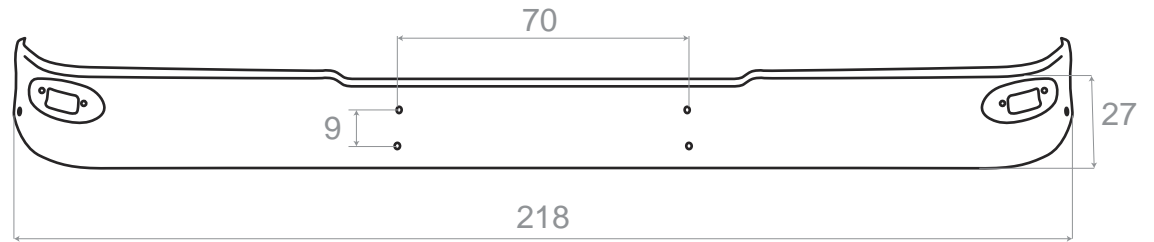

(cm)

extra



**240/415**

**KIT** (240/416+240/417)

**240/416**

d-rh-rechts

500314717

**240/417**

s-lh-links

500314716



**240/480**

-



COVERED

440/400 504107239

materiale | material | material PMMA - Acrylglas

peso | weight | Gewicht 2,920 Kg

applicabilità | suitable to | für IVECO Eurostar  
tetto alto | high roof | hohes Dach

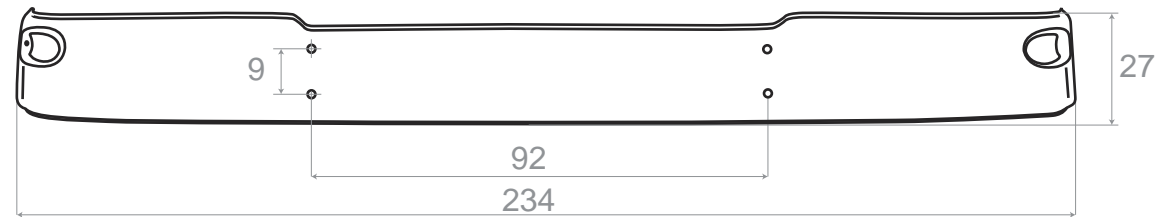

(cm)

extra



540/415 -  
KIT (540/416+540/417)

540/416 504047265  
d-rh-rechts

540/417 504047264  
s-lh-links



440/480 -



**440/405** 500338393

materiale | material | material PMMA - Acrylglas

peso | weight | Gewicht 3,125 Kg

applicabilità | suitable to | für IVECO Eurostar

tetto basso | low roof | niedriges Dach

tetto medio | medium roof | mittelhohes Dach

tetto alto | high roof | hohes Dach

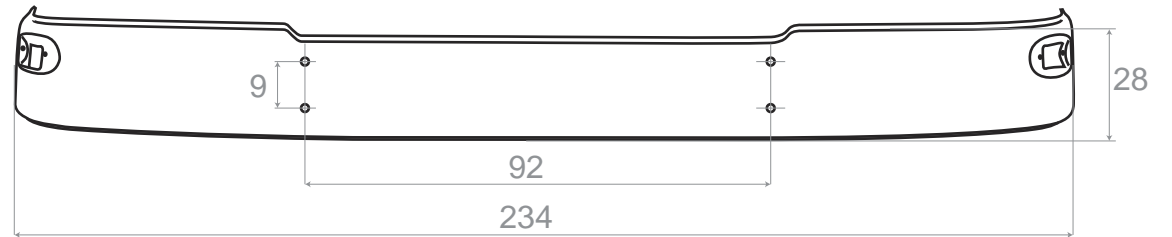

(cm)

extra



**240/415**  
KIT (240/416+240/417)

**240/416** 500314717  
d-rh-rechts

**240/417** 500314716  
s-lh-links



**440/480** -



COVERING

580/400 5801715565

materiale | material | material PMMA - Acrylglas

peso | weight | Gewicht 4,670 Kg

applicabilità | suitable to | für IVECO AS Stralis 2013  
IVECO AS Stralis X-WAY

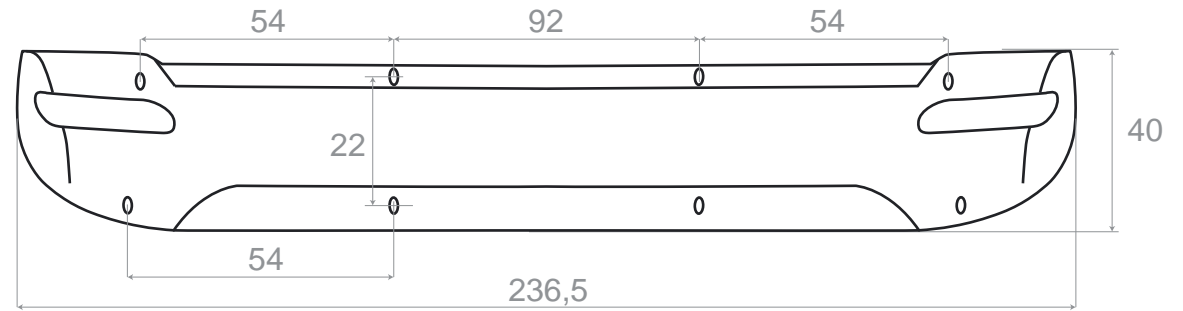

(cm)

extra



COVIND

**580/405** 5801715566

materiale | material | material PMMA - Acrylglas

peso | weight | Gewicht 4,90 Kg

applicabilità | suitable to | für IVECO AD-AT Stralis 2013  
IVECO AD-AT Stralis X-WAY

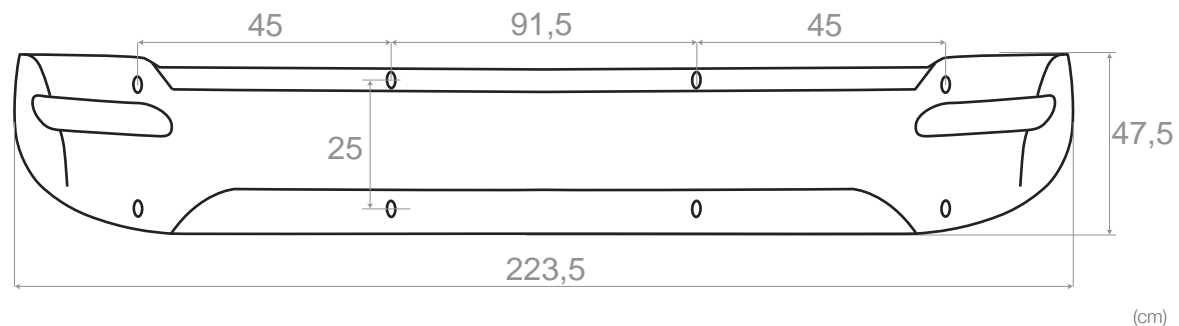

extra



COVERING

gallery

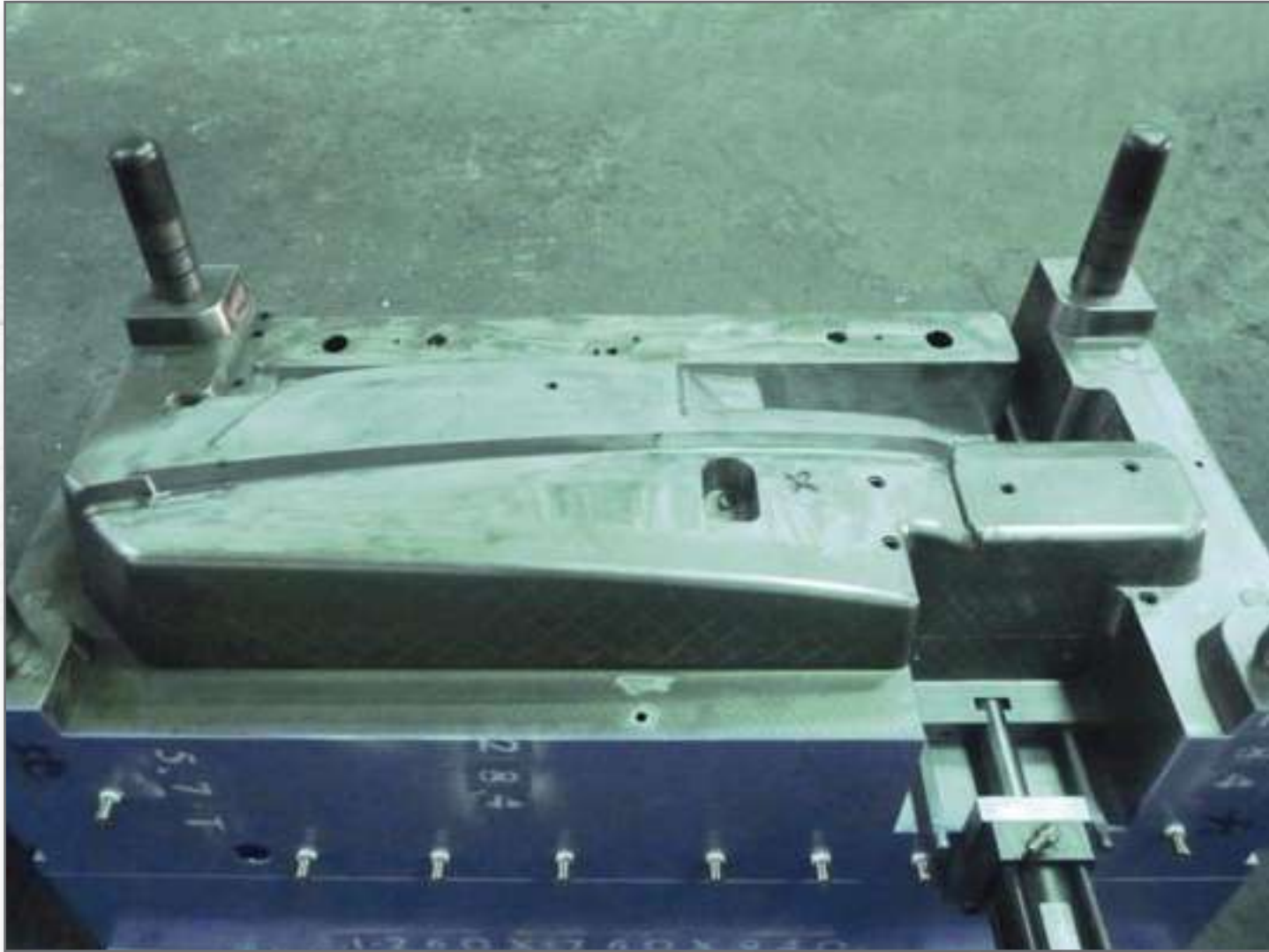

COVIND

gallery



COVIND

**TGL/400** 81637010055  
81637010058

materiale | material | material PMMA - Acrylglas

peso | weight | Gewicht 4,105 Kg

applicabilità | suitable to | für MAN TGL 10-12  
cabina corta | short cab | kurze Kabine

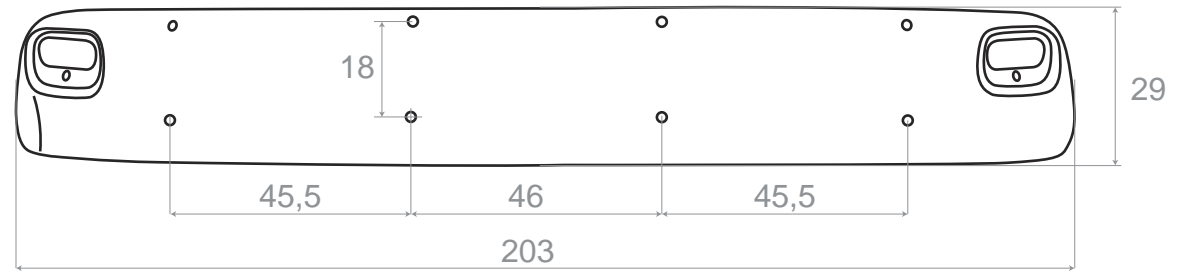

(cm)



**MLX/480** 81637350032



**MLX/405** 81637010060  
81637010047

materiale | material | material PMMA - Acrylglas

peso | weight | Gewicht 5,125 Kg

applicabilità | suitable to | für  
MAN TGL  
MAN TGS M-L  
MAN TGA M-L  
MAN TGL L

tetto basso | low roof | niedriges Dach

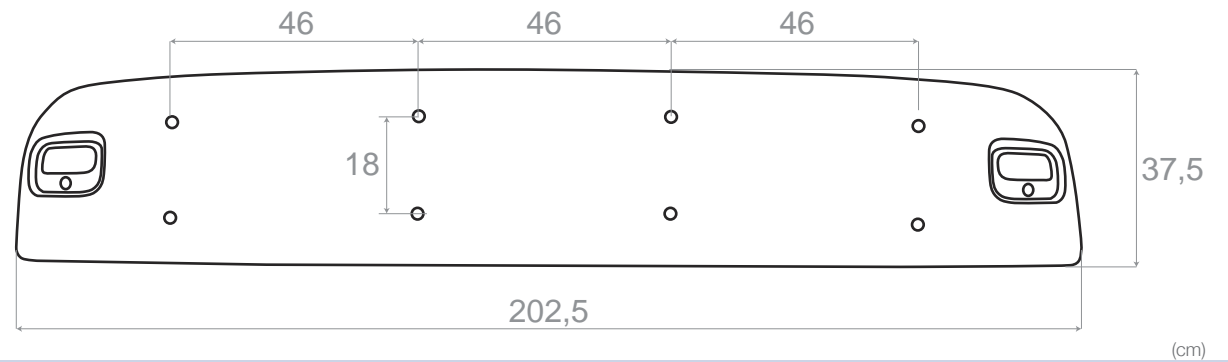

**MLX/480** 81637350032



TGX/400 81637010044  
81637010033

materiale | material | material PMMA - Acrylglas

peso | weight | Gewicht 5,810 Kg

applicabilità | suitable to | für MAN TGX  
MAN TGA XXL

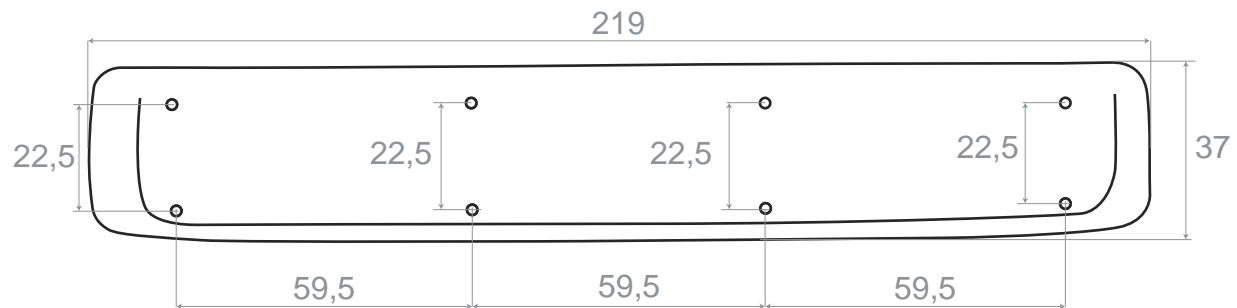

(cm)



TGX/480 81637350029  
81637310282



**XXL/405** 81637010062  
81637010048

materiale | material | material PMMA - Acrylglas

peso | weight | Gewicht 5,940 Kg

applicabilità | suitable to | für MAN TGA XL/XXL 04/2004 →  
tetto basso | low roof | niedriges Dach  
MAN TGX XL

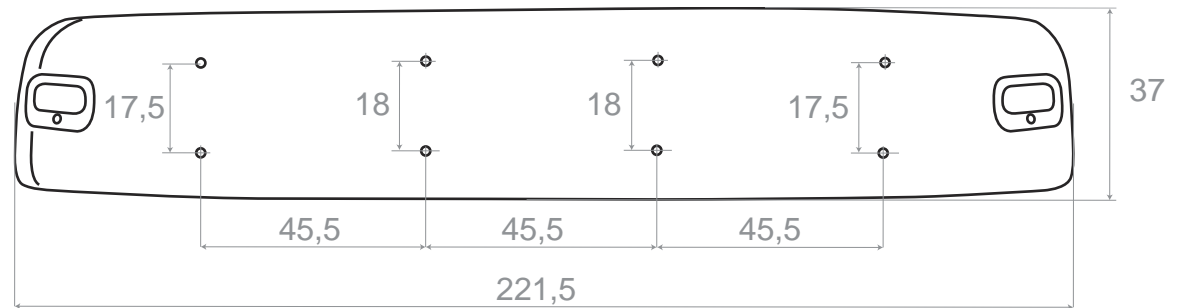

(cm)

extra



**MLX/480** 81637350032



COVERING

**XXL/410** 81637010057

materiale | material | material PMMA - Acrylglas

peso | weight | Gewicht 4,650 Kg

applicabilità | suitable to | für MAN TGX XLX  
MAN TGA XL-XXL-XXL

tetto medio | medium roof | mittelhohes Dach

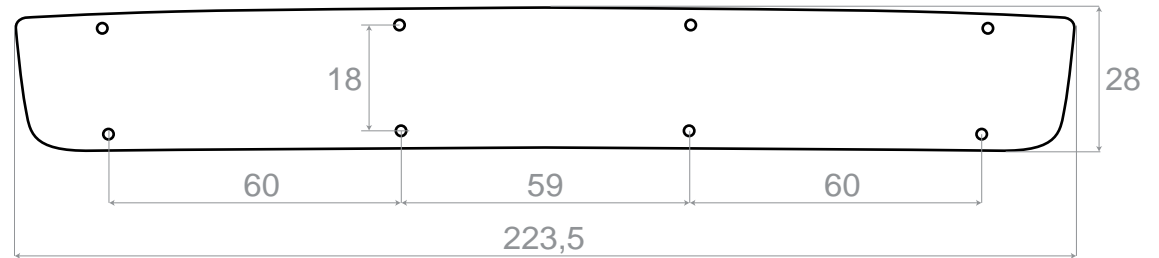

(cm)



**XXL/490**

81637350028  
81637310283



**XXL/415** 81637010046  
81637010031

materiale | material | material PMMA - Acrylglas

peso | weight | Gewicht 4,00 Kg

applicabilità | suitable to | für MAN TGA LX  
MAN TGX LX

cabina alta | Hohe Fhs | hohe Kabine

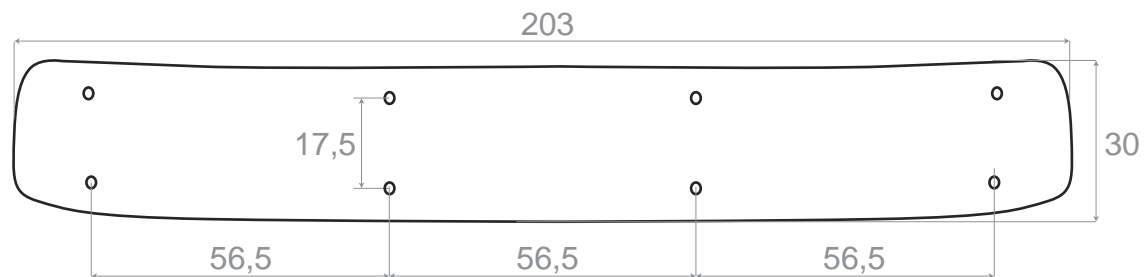

(cm)

extra



**XXL/490**

81637350028  
81637310283



**L20/480** 85637010010  
81637010024

materiale | material | material PMMA - Acrylglas

peso | weight | Gewicht 2,950 Kg

applicabilità | suitable to | für MAN LE 2000

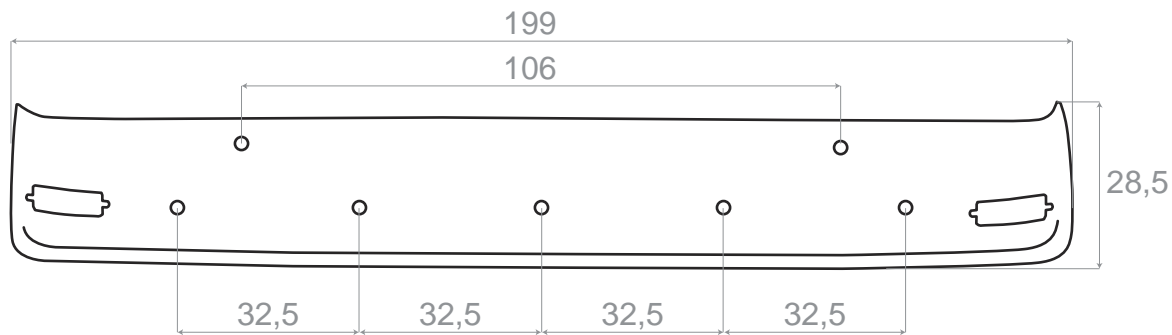

(cm)

extra



**COVIND**

**F90/400** 81637010010  
81991828761

materiale | material | material PMMA - Acrylglas

peso | weight | Gewicht 3,725 Kg

applicabilità | suitable to | für MAN F90

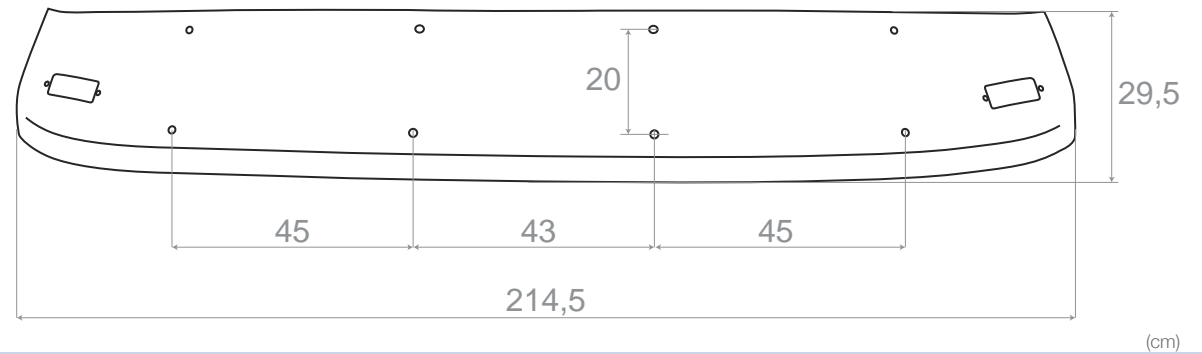

**M20/480** 81637350024



**M20/485** -



**M20/400** 81637010021  
81991828764

materiale | material | material PMMA - Acrylglas

peso | weight | Gewicht 4,065 Kg

applicabilità | suitable to | für MAN F2000

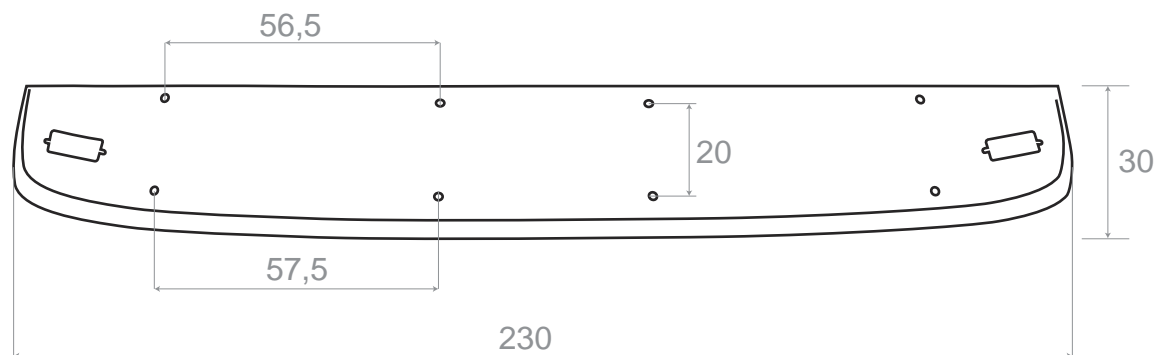

(cm)



**M20/480** 81637350024



**M20/485** -



gallery



COVIND

973/400 9738110410

materiale | material | material PMMA - Acrylglas

peso | weight | Gewicht 3,230 Kg

applicabilità | suitable to | für MERCEDES-BENZ Atego 1-2  
MERCEDES-BENZ Axor 1-2  
→2004

tetto basso | low roof | niedriges Dach

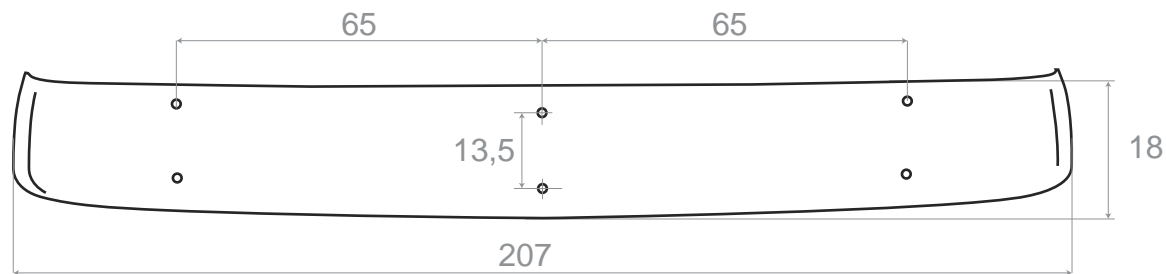

MERCEDES-BENZ

extra



973/480 9738101514



# suitab MERCEDES-BENZ

973/405 9738110610  
9738110710

materiale | material | material PMMA - Acrylglas

peso | weight | Gewicht 2,280 Kg

applicabilità | suitable to | für MERCEDES-BENZ Atego 1-2  
MERCEDES-BENZ Axor 1-2  
tetto basso | low roof | niedriges Dach

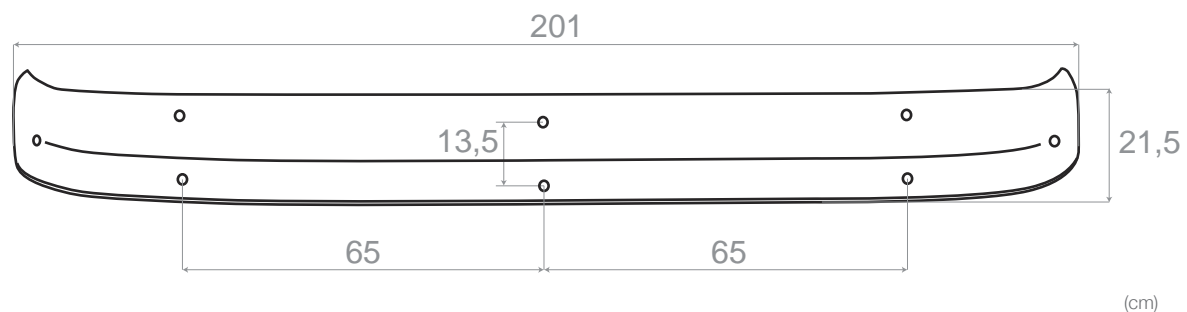

973/490 0028100614



973/410 9738111010

materiale | material | material PMMA - Acrylglas

peso | weight | Gewicht 2,375 Kg

applicabilità | suitable to | für MERCEDES-BENZ Atego 1-2  
MERCEDES-BENZ Axor 1-2  
tetto basso | low roof | niedriges Dach



MERCEDES-BENZ

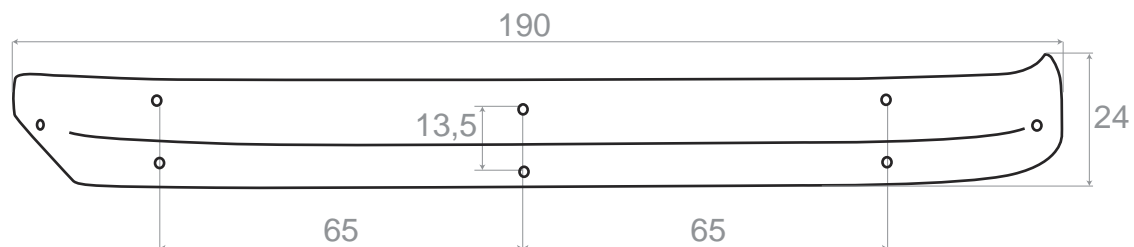

(cm)



973/485 0028101714



# suitab MERCEDES-BENZ

670/400 6738110010

materiale | material | material PMMA - Acrylglas

peso | weight | Gewicht 4,790 Kg

applicabilità | suitable to | für  
MERCEDES-BENZ 670  
MERCEDES-BENZ 673  
MERCEDES-BENZ LN814

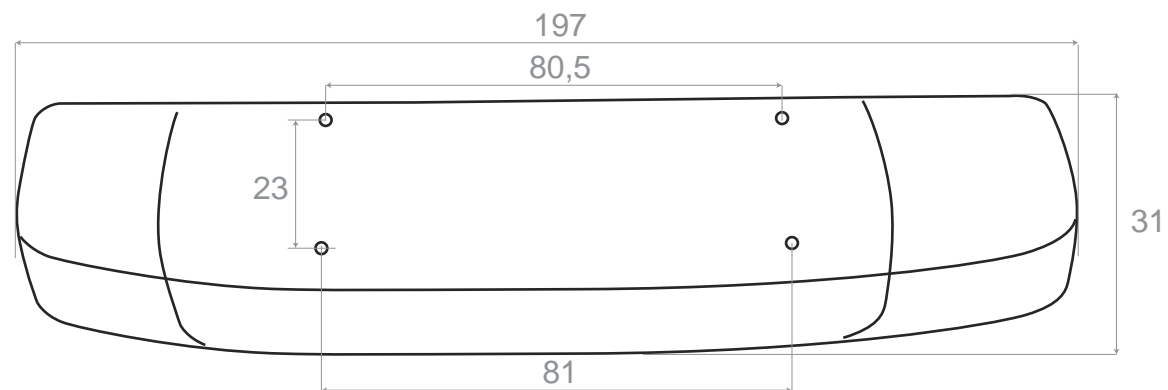

(cm)



670/480 6738110814



940/400 9738110310

materiale | material | material PMMA - Acrylglas

peso | weight | Gewicht 2,670 Kg

applicabilità | suitable to | für MERCEDES-BENZ Axor 1-2  
→2004

tetto alto | high roof | hohes Dach

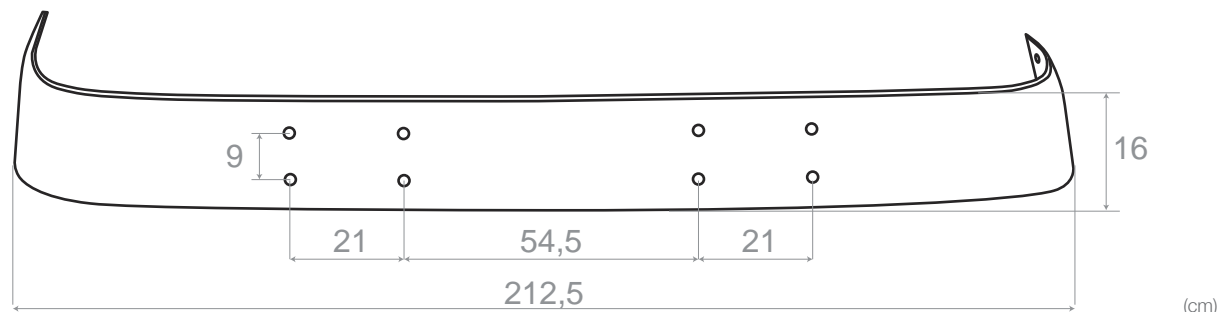

extra



940/480 9738100014

tetto alto | high roof | hohes Dach

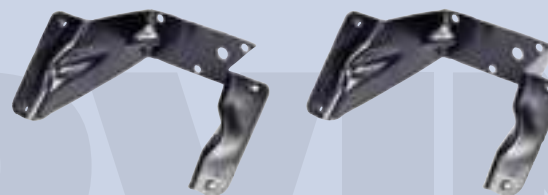

COVERND

# suitable to MERCEDES-BENZ

940/405 9738110510

materiale | material | material PMMA - Acrylglas

peso | weight | Gewicht 2,485 Kg

applicabilità | suitable to | für MERCEDES-BENZ Axor 1-2  
→2004  
tetto alto | high roof | hohes Dach

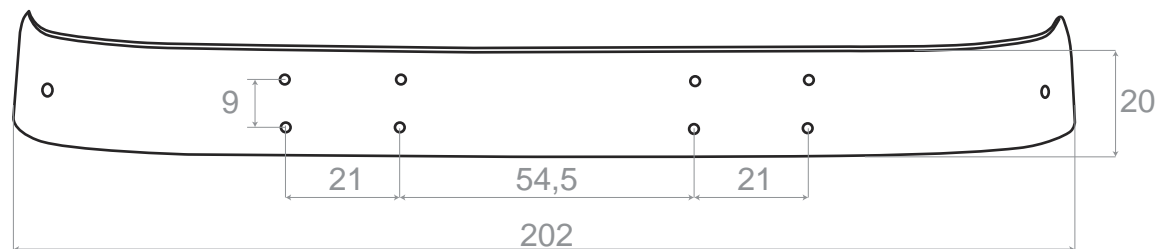

(cm)

extra



940/485 0028100514



940/410 9738110810

materiale | material | material PMMA - Acrylglas

peso | weight | Gewicht 2,315 Kg

applicabilità | suitable to | für MERCEDES-BENZ Axor 1-2  
→2004

tetto alto | high roof | hohes Dach



MERCEDES-BENZ

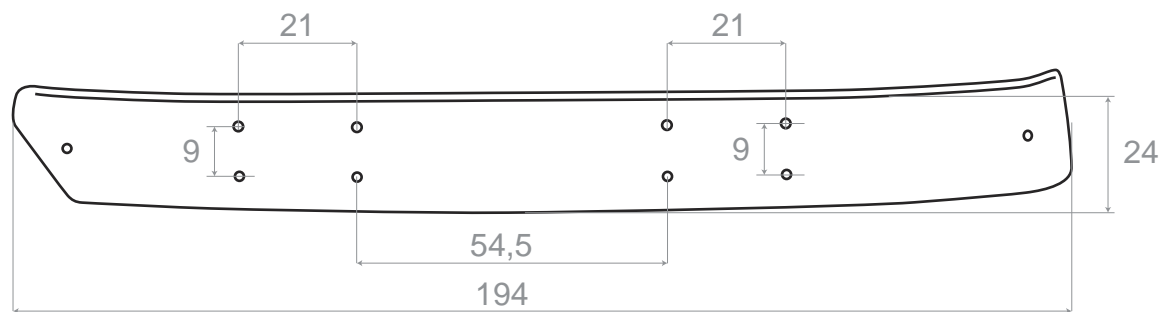

(cm)

extra



940/490 -



# suitable to MERCEDES-BENZ

960/400 9608112310  
9608110110

materiale | material | material PMMA - Acrylglas

peso | weight | Gewicht 3,480 Kg

applicabilità | suitable to | für MERCEDES-BENZ Actros 4  
Stream Space 1  
Big space  
Giga space

cabina | cab | Fhs 2500 mm

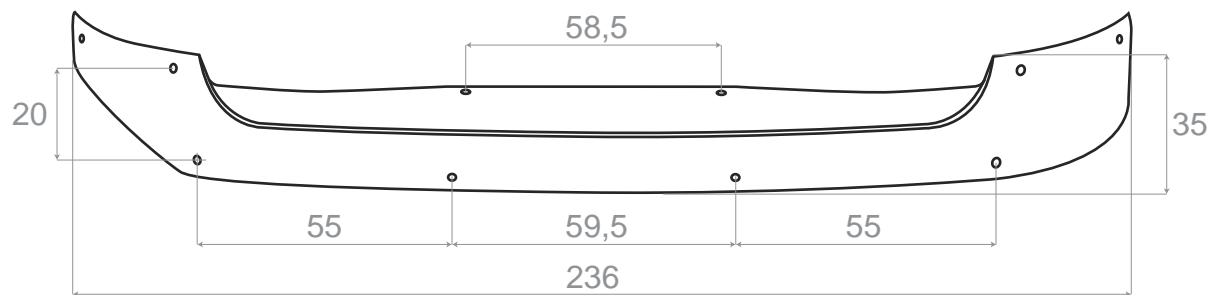

(cm)



# COVIND

# suitable MERCEDES-BENZ

960/405 9608112210  
9608110010

materiale | material | material PMMA - Acrylglas

peso | weight | Gewicht 2,920 Kg

applicabilità | suitable to | für MERCEDES-BENZ Actros 4  
Classic Space 1-2  
Stream Space 1-2

cabina | cab | Fhs. 2300 mm



MERCEDES-BENZ

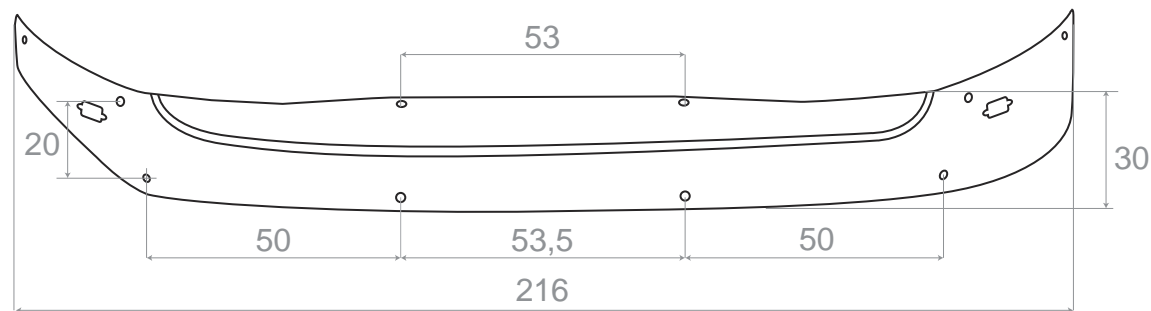

(cm)

extra



# COVIND

# suitable to MERCEDES-BENZ

960/410 9608104610  
9608102610

materiale | material | material PMMA - Acrylglas

peso | weight | Gewicht 3,360 Kg

applicabilità | suitable to | für MERCEDES-BENZ Actros 4  
Classic Space 1-2  
Stream Space 1-2

cabina | cab | Fhs. 2300 mm

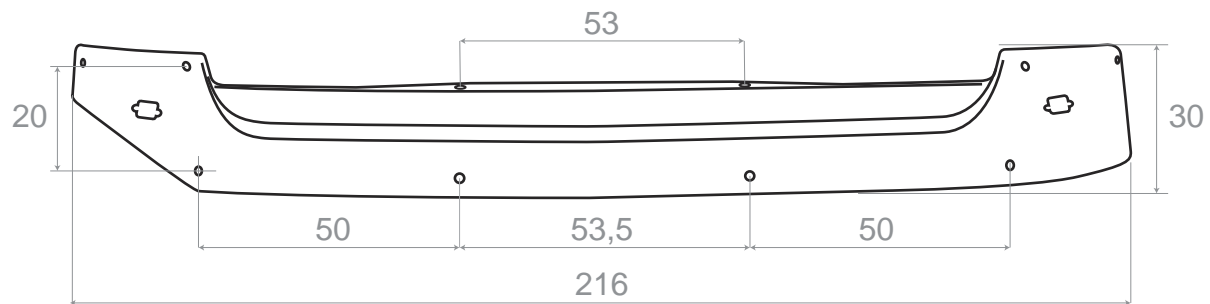

(cm)



# COVIND

# suitable MERCEDES-BENZ

960/415 9608112410  
9608110610

materiale | material | material PMMA - Acrylglas

peso | weight | Gewicht 2,770 Kg

applicabilità | suitable to | für MERCEDES-BENZ Actros 4  
Classic Space 1-2  
Stream Space 1-2

cabina | cab | Fhs. 2300 mm

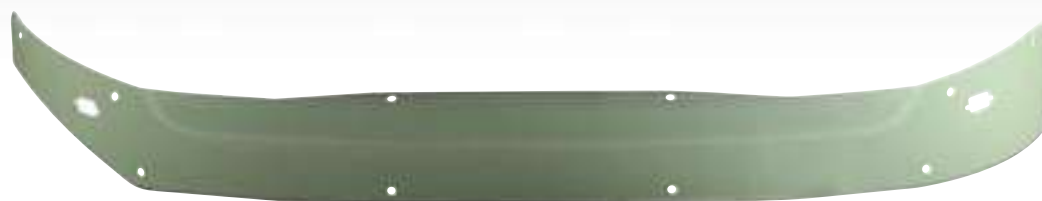

MERCEDES-BENZ

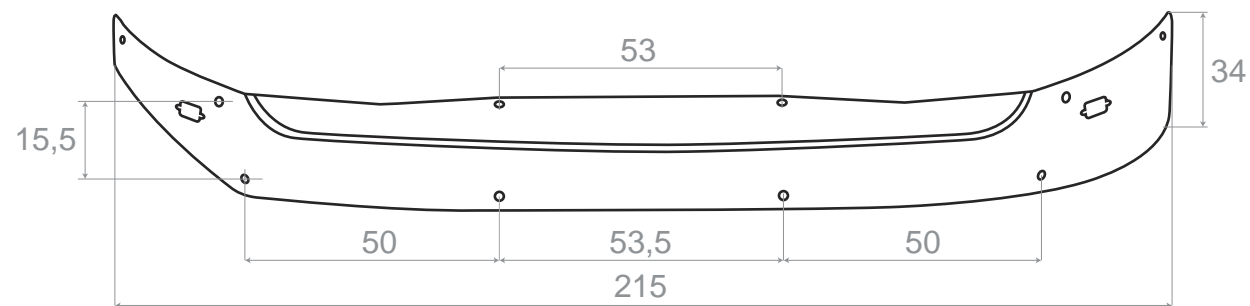

(cm)

extra



# COVIND

# suitable to MERCEDES-BENZ

960/420 9608104810  
9608102310

materiale | material | material PMMA - Acrylglas

peso | weight | Gewicht 3,455 Kg

applicabilità | suitable to | für MERCEDES-BENZ Actros 4  
Classic Space 1-2  
Stream Space 1-2

cabina | cab | Fhs. 2300 mm

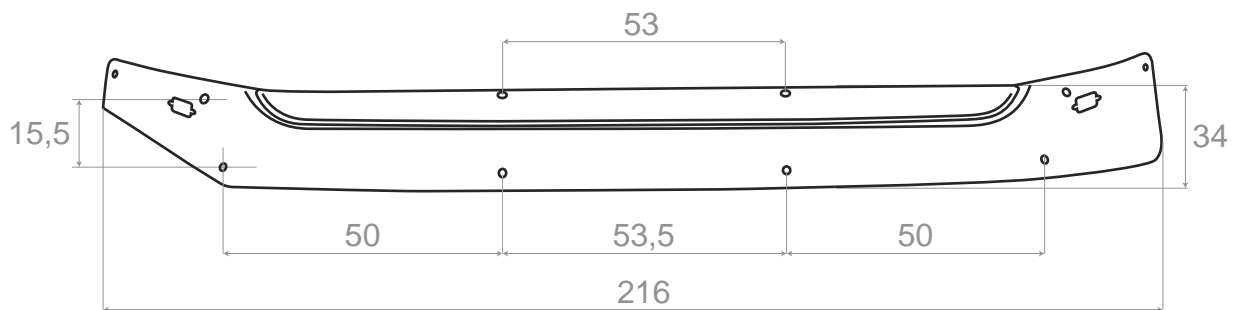

(cm)



# COVIND

# suitable MERCEDES-BENZ

960/425 9608105210  
9608102910

materiale | material | material PMMA - Acrylglas

peso | weight | Gewicht 4,110 Kg

applicabilità | suitable to | für MERCEDES-BENZ Actros 4  
Stream Space 1  
Big space  
Giga space  
cabina | cab | Fhs. 2500 mm



MERCEDES-BENZ

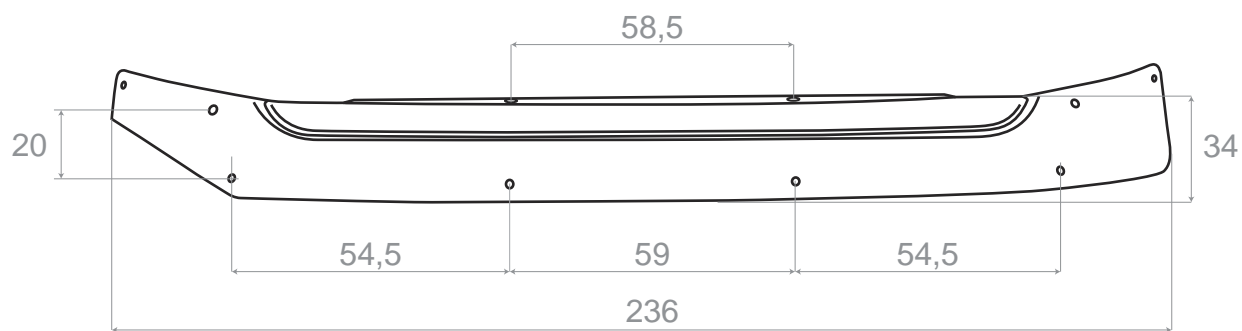

(cm)

extra



# COVIND

# suitable to MERCEDES-BENZ

960/430 9608113010  
9608111210

materiale | material | material PMMA - Acrylglas

peso | weight | Gewicht 2,760 Kg

applicabilità | suitable to | für MERCEDES-BENZ Actros 4  
Stream Space 1  
Big space  
Giga space

cabina | cab | Fhs. 2500 mm

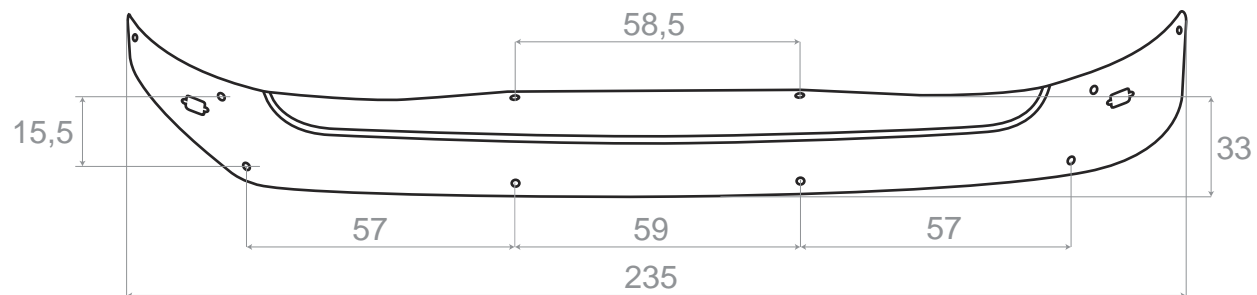

(cm)



# COVIND

# suitable to MERCEDES-BENZ

960/435 9608105510  
9608103210

materiale | material | material PMMA - Acrylglas

peso | weight | Gewicht 4,015 Kg

applicabilità | suitable to | für MERCEDES-BENZ Actros 4  
Stream Space 1  
Big space  
Giga space  
cabina | cab | Fhs. 2500 mm



MERCEDES-BENZ

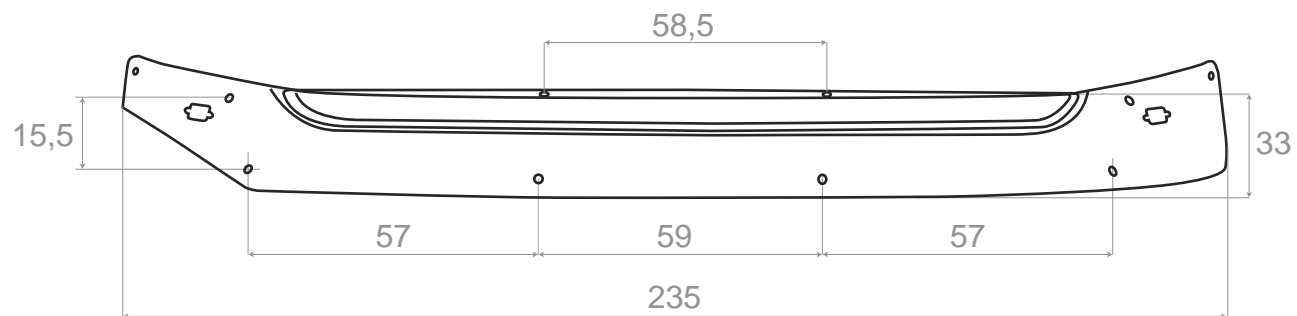

(cm)

extra



# COVIND

# suitable MERCEDES-BENZ

943/400 9438111210

materiale | material | material PMMA - Acrylglas

peso | weight | Gewicht 3,035 Kg

applicabilità | suitable to | für MERCEDES-BENZ Actros 2  
2003→  
MERCEDES-BENZ Actros 2  
MEGA SPACE →2003  
tetto basso | low roof | niedriges Dach

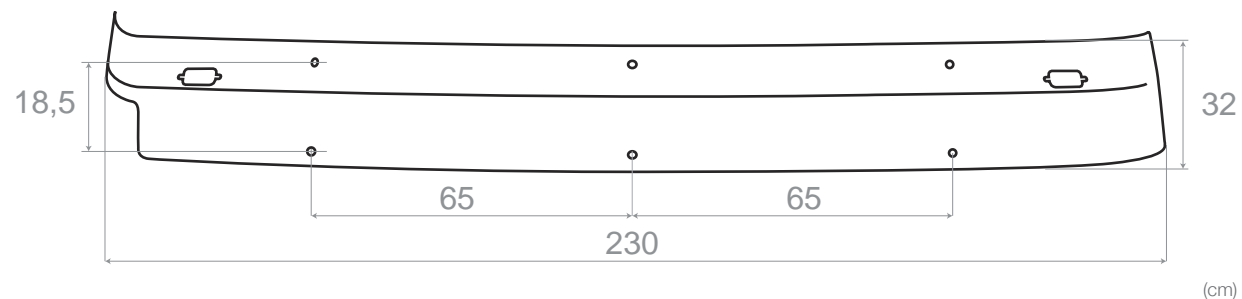

(cm)



943/485 9438100814



943/405 9438110210

materiale | material | material PMMA - Acrylglas

peso | weight | Gewicht 3,305 Kg

applicabilità | suitable to | für MERCEDES-BENZ Actros 2  
2003→  
MERCEDES-BENZ Actros 2  
MEGA SPACE 2003→  
tetto basso | low roof | niedriges Dach



MERCEDES-BENZ

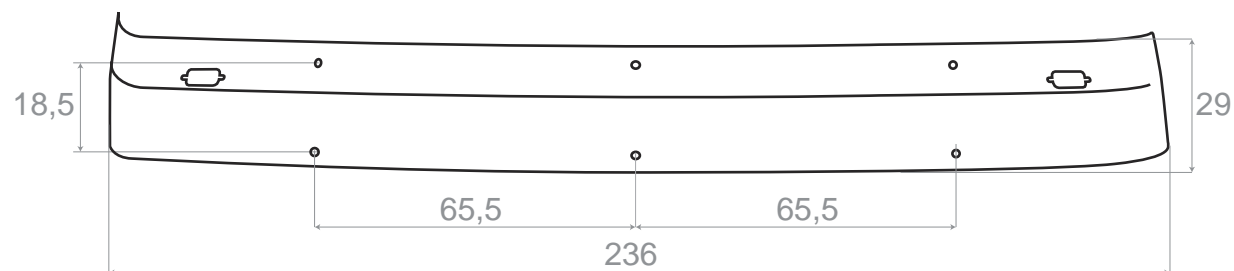

(cm)



943/490 9438100914



# suitable MERCEDES-BENZ

943/410 9438110010

materiale | material | material PMMA - Acrylglas

peso | weight | Gewicht 3,335 Kg

applicabilità | suitable to | für MERCEDES-BENZ Actros 2  
2003→  
MERCEDES-BENZ Actros 2  
Mega Space 2003→  
tetto alto | high roof | hohes Dach

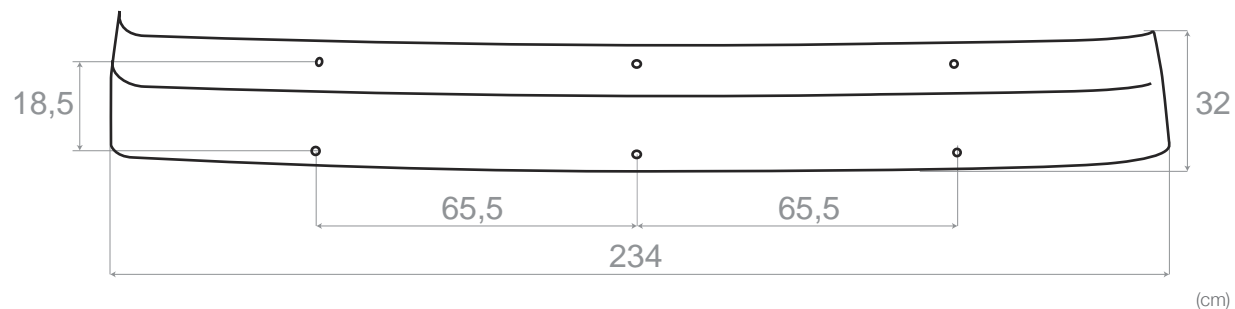

943/485 9438100814



# COVERING

# suitable MERCEDES-BENZ

943/415 9438111010

materiale | material | material PMMA - Acrylglas

peso | weight | Gewicht 3,190 Kg

applicabilità | suitable to | für MERCEDES-BENZ Actros 2  
2003→  
MERCEDES-BENZ Actros 2  
Mega Space

tetto alto | high roof | hohes Dach



MERCEDES-BENZ

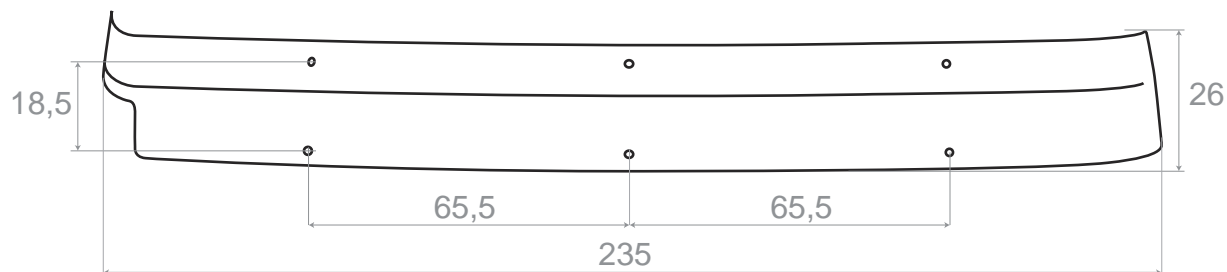

(cm)



943/485 9438100814



# suitable MERCEDES-BENZ

943/420 9438100610

materiale | material | material PMMA - Acrylglas

peso | weight | Gewicht 3,000 Kg

applicabilità | suitable to | für MERCEDES-BENZ Actros 3  
2008-2012  
MERCEDES-BENZ Actros 3  
Mega Space

tetto alto | high roof | hohes Dach

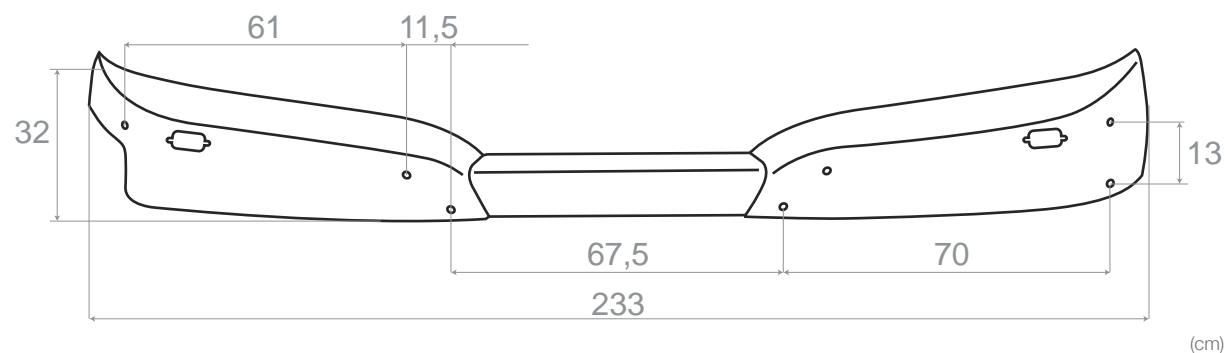

943/495 9438101714



# suitable to MERCEDES-BENZ

943/425 9438100410

materiale | material | material PMMA - Acrylglas

peso | weight | Gewicht 3,000 Kg

applicabilità | suitable to | für MERCEDES-BENZ Actros 3  
2008-2012  
MERCEDES-BENZ Actros 3  
Mega Space

tetto alto | high roof | hohes Dach



MERCEDES-BENZ

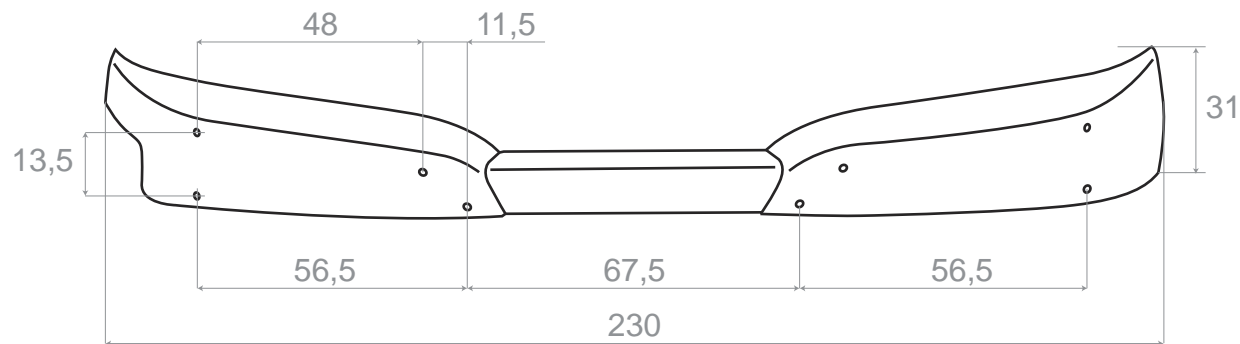

(cm)



943/480 9438101614



# suitab MERCEDES-BENZ

943/430 9438100810

materiale | material | material PMMA - Acrylglas

peso | weight | Gewicht 3,000 Kg

applicabilità | suitable to | für MERCEDES-BENZ Actros 3  
2008-2012  
MERCEDES-BENZ Actros 3  
Mega Space

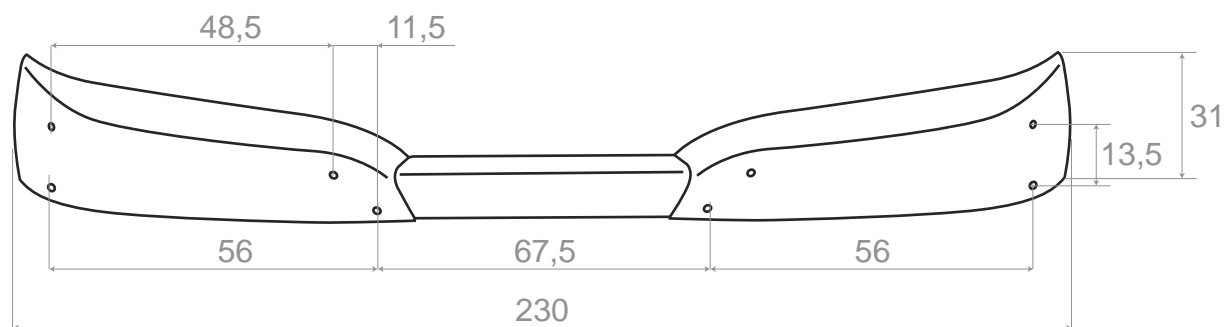

(cm)



943/480

9438101614



# suitable to MERCEDES-BENZ

943/435 9438100910

materiale | material | material PMMA - Acrylglas

peso | weight | Gewicht 3,050 Kg

applicabilità | suitable to | für MERCEDES-BENZ Actros 3  
2008-2012  
MERCEDES-BENZ Actros 3  
Mega Space

cabina bassa | low cab | niedrige Kabine



MERCEDES-BENZ

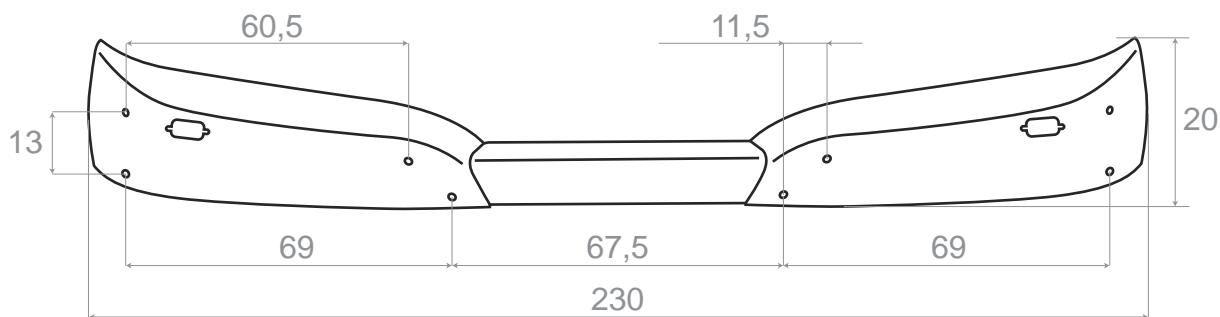

(cm)

extra



# COVIND

# suitable to MERCEDES-BENZ

941/400 9418110810

materiale | material | material PMMA - Acrylglas

peso | weight | Gewicht 7,930 Kg

applicabilità | suitable to | für MERCEDES-BENZ Actros 1  
1996-2003

cabina bassa | low cab | niedrige Kabine

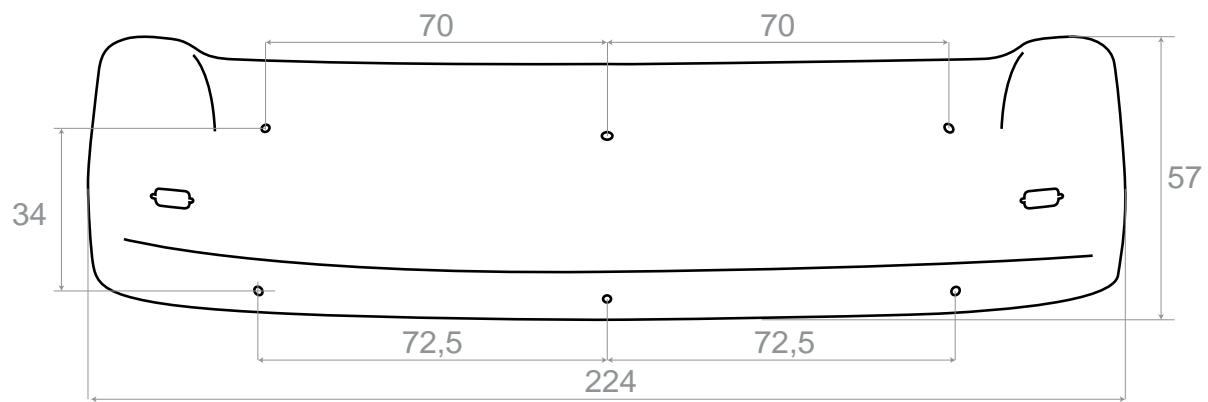
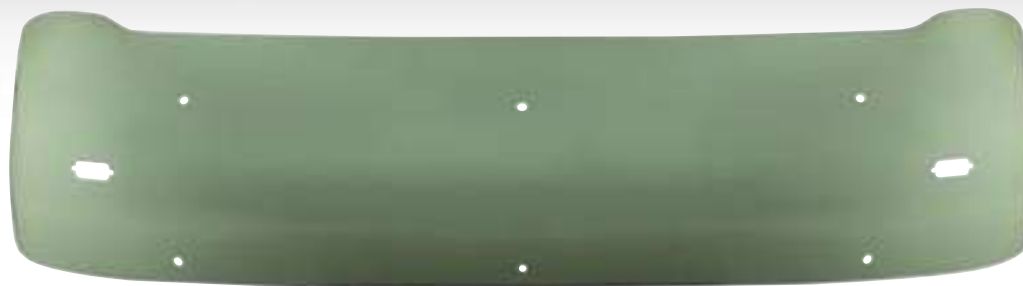

(cm)



# COVIND

941/405 9418110610  
9418110010

materiale | material | material PMMA - Acrylglas

peso | weight | Gewicht 7,930 Kg

applicabilità | suitable to | für MERCEDES-BENZ Actros 1  
→2003

tetto basso | low roof | niedriges Dach



MERCEDES-BENZ

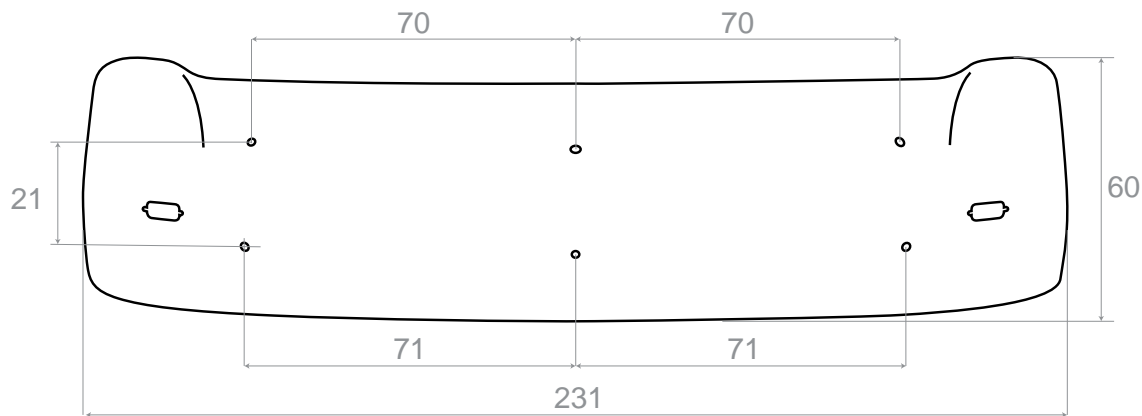

(cm)

extra



COVIND

# suitable to MERCEDES-BENZ

941/410 9418100010

materiale | material | material PMMA - Acrylglas

peso | weight | Gewicht 5,635 Kg

applicabilità | suitable to | für MERCEDES-BENZ Actros 1  
Mega Space →2003  
tetto alto | high roof | hohes Dach

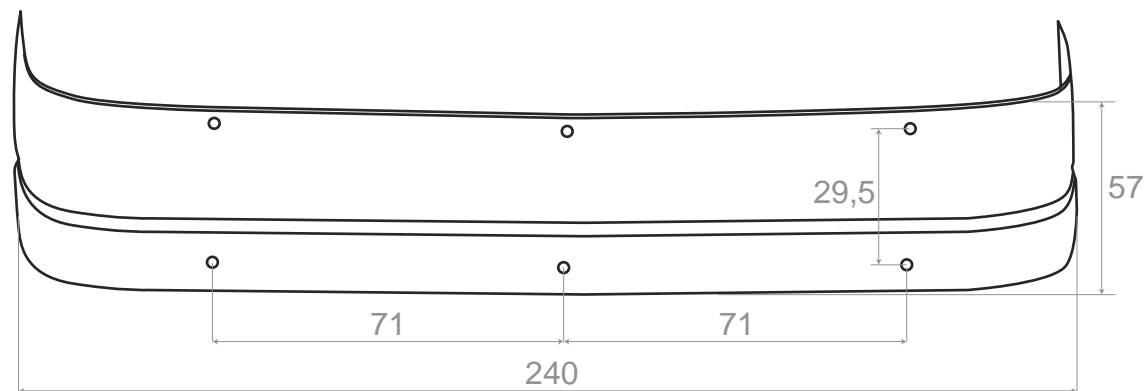

(cm)



941/480 9418101114



# suitable MERCEDES-BENZ

941/415 9418101010

materiale | material | material PMMA - Acrylglas

peso | weight | Gewicht 5,725 Kg

applicabilità | suitable to | für MERCEDES-BENZ Actros 1  
Mega Space →2003  
tetto alto | high roof | hohes Dach



MERCEDES-BENZ

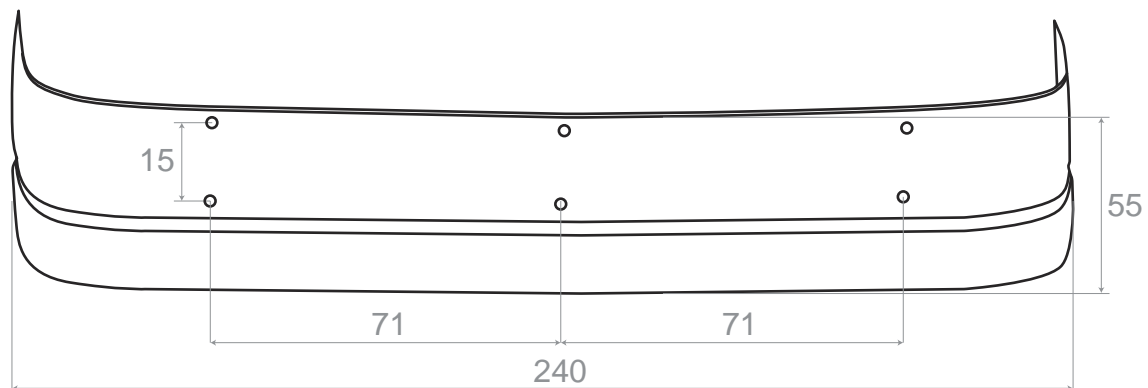

(cm)

extra



941/485 9418100714



# suitable to MERCEDES-BENZ

641/400 3818112710

materiale | material | material PMMA - Acrylglas

peso | weight | Gewicht 5,755 Kg

applicabilità | suitable to | für MERCEDES-BENZ 641  
tetto basso | low roof | niedriges Dach

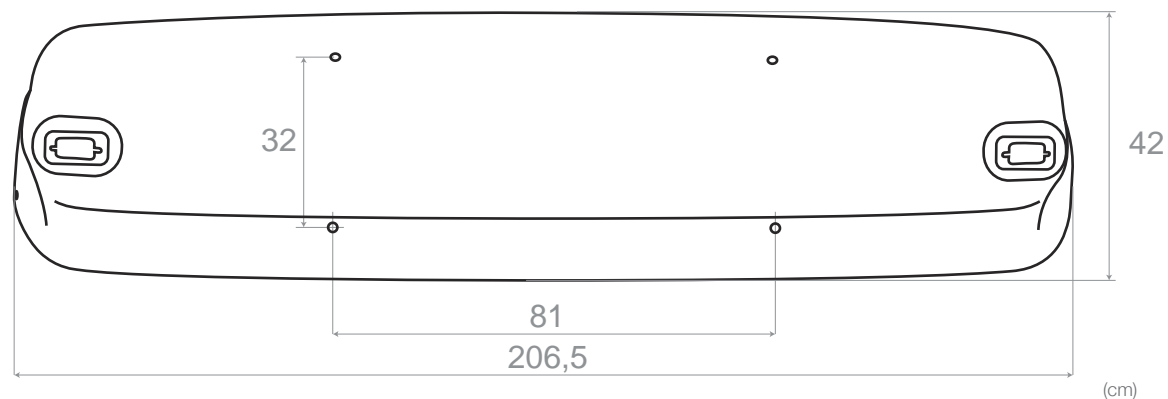

extra



641/480 3818111014



# suitable to MERCEDES-BENZ

649/480 3898110010

materiale | material | material PMMA - Acrylglas

peso | weight | Gewicht 6,920 Kg

applicabilità | suitable to | für MERCEDES-BENZ 389  
MERCEDES-BENZ 649

tetto normale | normal roof | normales Dach

tetto alto | high roof | hohes Dach



MERCEDES-BENZ

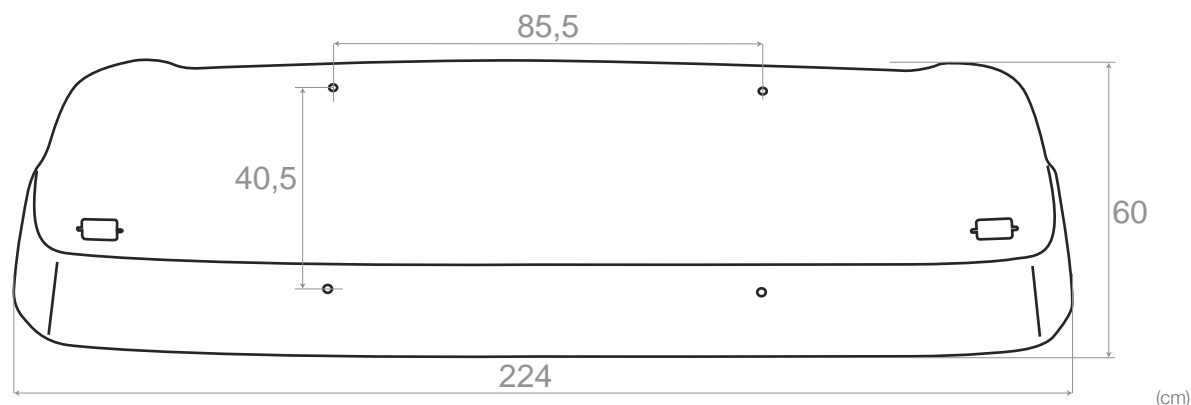

extra



# COVIND

# suitab MERCEDES-BENZ

381/400 3818112510

materiale | material | material PMMA - Acrylglas

peso | weight | Gewicht 6,650 Kg

applicabilità | suitable to | für MERCEDES-BENZ 381  
MERCEDES-BENZ 641

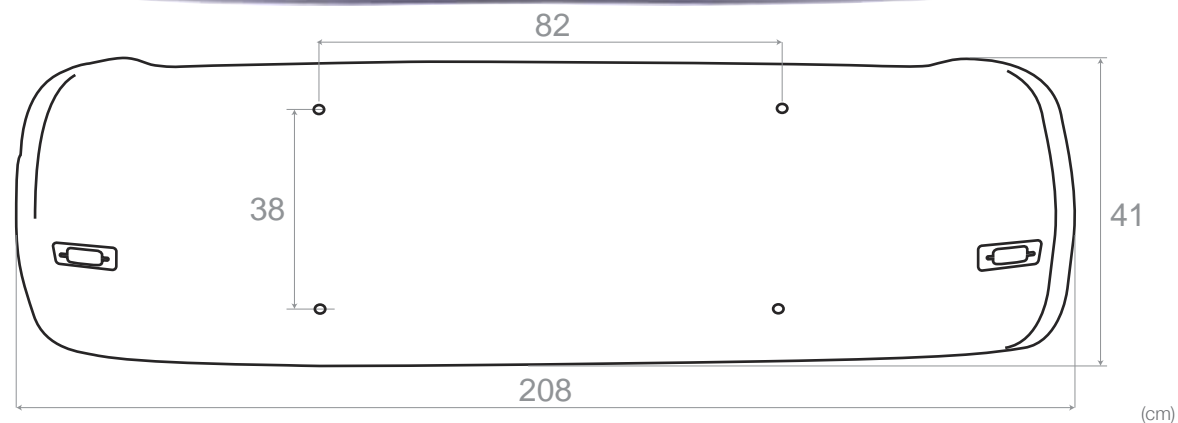

extra



381/480 -



gallery



COVIND

gallery



COVIND

**MDL/400** 7420937410  
7420937430

materiale | material | material PMMA - Acrylglas

peso | weight | Gewicht 4,885 Kg

applicabilità | suitable to | für RENAULT Midlum 1- 2  
cabina | cab | Fhs. 1950 mm



RENAULT

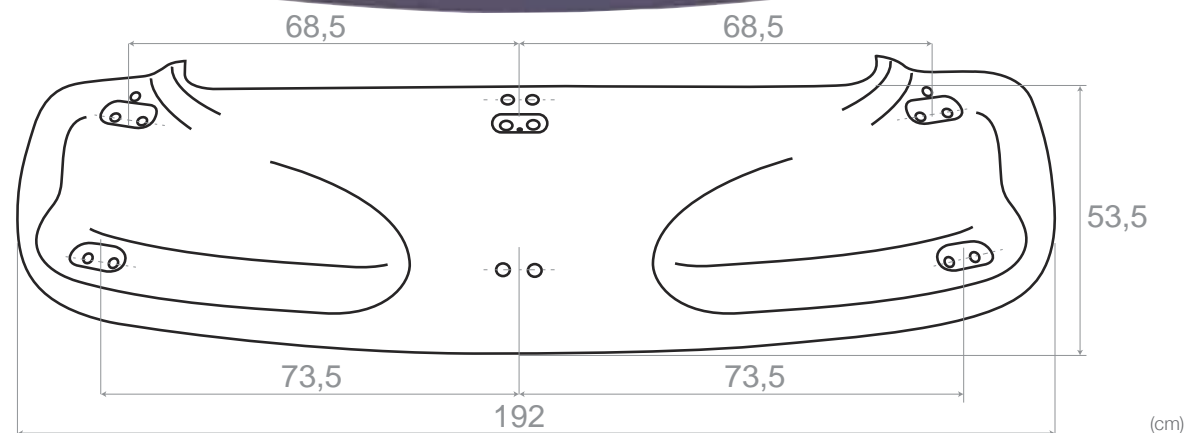

extra



COVIND

**PRM/405** 5010578255

materiale | material | material PMMA - Acrylglas

peso | weight | Gewicht 1,980 Kg

applicabilità | suitable to | für RENAULT New Premium  
 RENAULT Midlum 2  
 tetto alto | high roof | hohes Dach

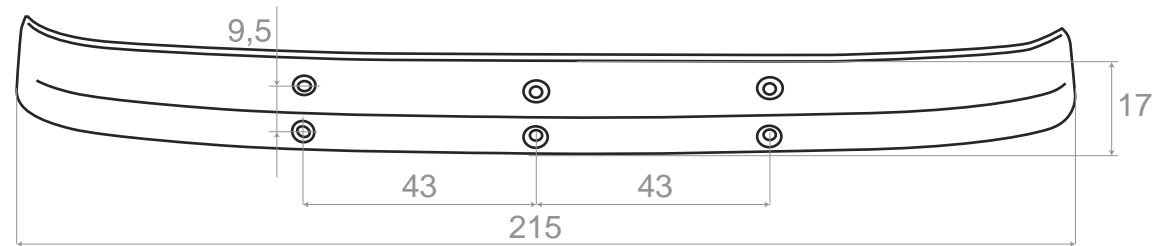

(cm)

extra



**PRM/415** 7482644956  
5010578256



**PRM/420** -



COVERING

**PRM/410** 5010578255

materiale | material | material PMMA - Acrylglas

peso | weight | Gewicht 1,980 Kg

applicabilità | suitable to | für RENAULT New Premium  
RENAULT Midlum 2  
tetto alto | high roof | hohes Dach

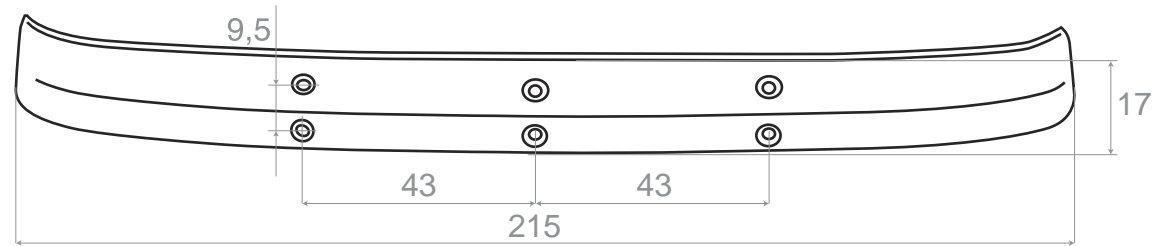

(cm)

extra



**PRM/415** 7482644956  
5010578256



**PRM/420** -



# COVERING

**385/400**

7420937418  
7420937442

materiale | material | material PMMA - Acrylglas

peso | weight | Gewicht 5,70 Kg

applicabilità | suitable to | für RENAULT Premium Lander  
RENAULT Kerax 1-2  
RENAULT Midlum 1-2

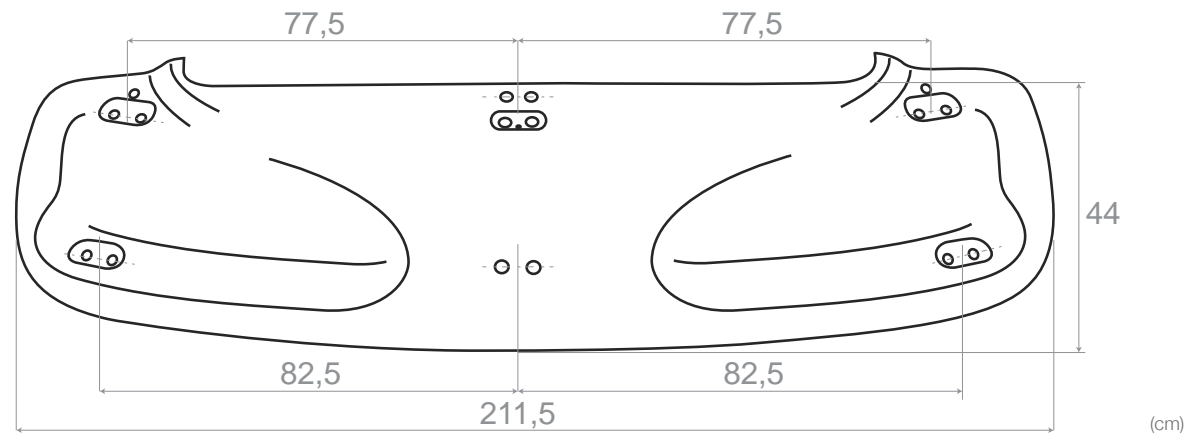

**385/480**

7420819179



gallery



COVIND

gallery

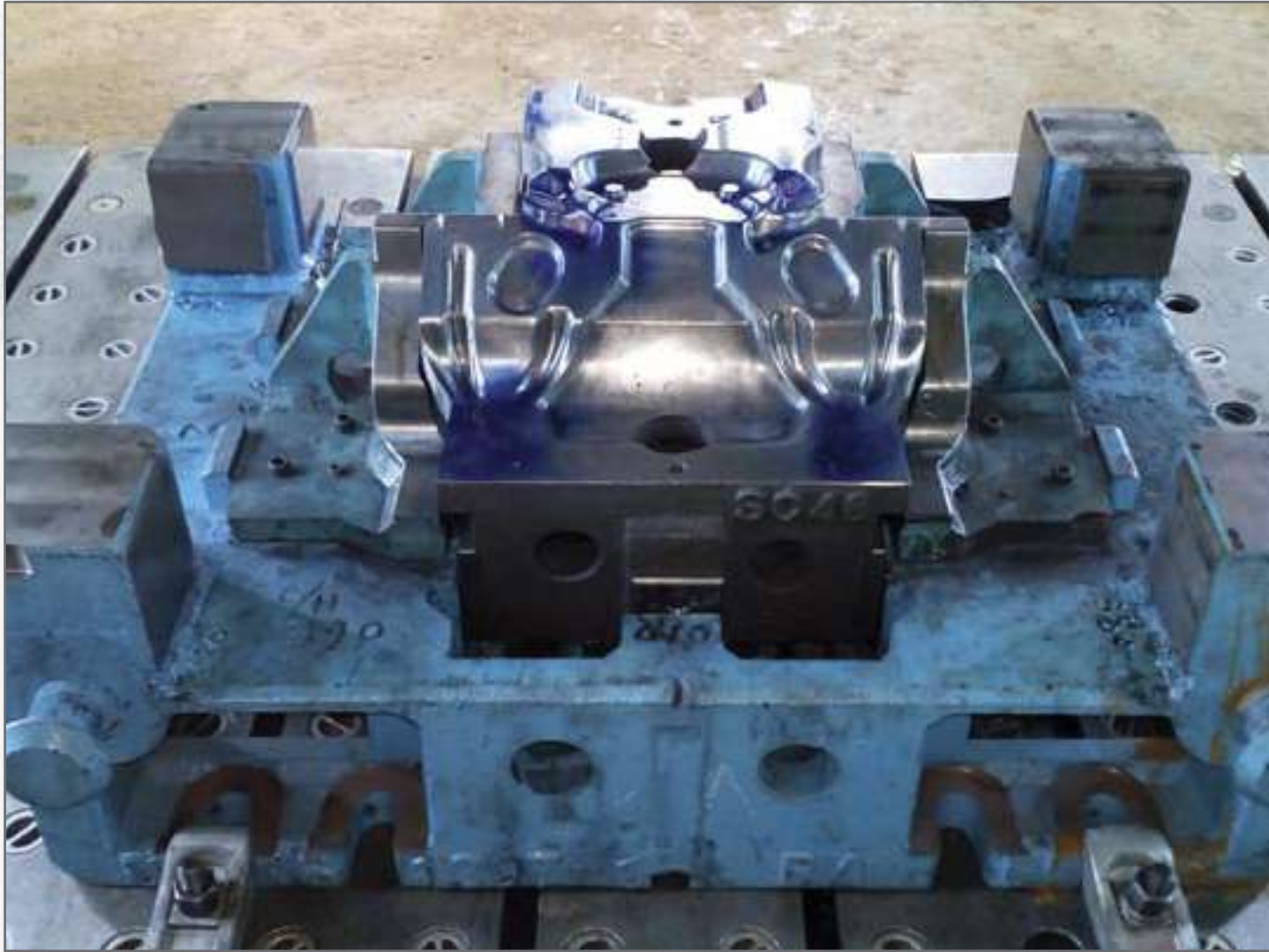

COVIND

**R50/400** 2541737  
2341420

materiale | material | material PC

peso | weight | Gewicht 1,945 Kg

applicabilità | suitable to | für SCANIA R 500  
SCANIA S 580  
SCANIA S 730



SCANIA

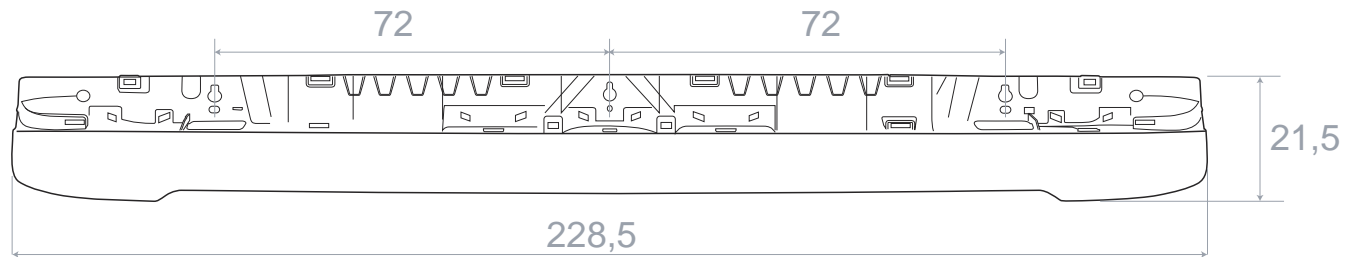

dimensioni (cm) | dimension (cm) | Größe (cm)(cm)

extra



**R50/405** 2341421  
2341423



**COVINDO**

**146/400** 2312092  
2055596

materiale | material | material Policarbonato

peso | weight | Gewicht 2,110 Kg

applicabilità | suitable to | für SCANIA R2010 CP Streamline  
SCANIA R2010 CG/CR Streamline

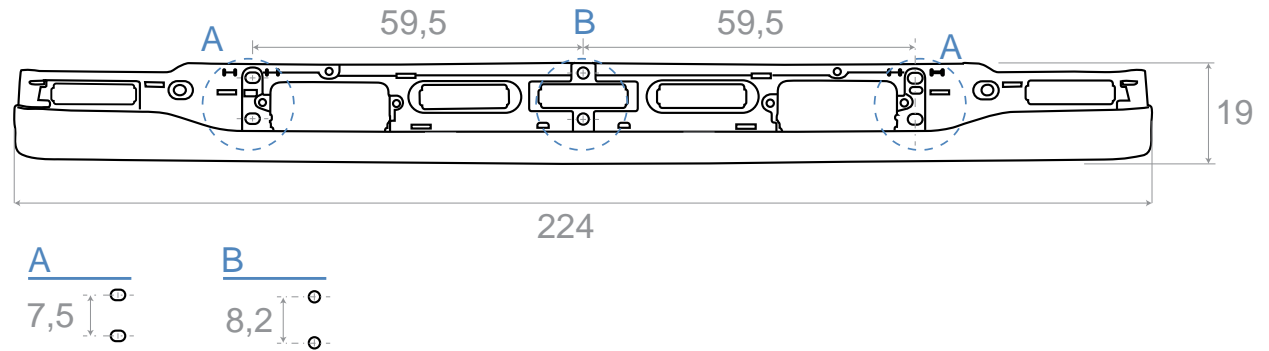

(cm)



**SCR/138** 2035104  
d/s-rh/lh-rechts/links 1910437





146/405

2312064  
2055591  
2117867



146/410

2312065  
2055592  
2117868



146/415

2312066  
2055593  
2117869



146/420

2312077  
2055594  
2117870



COVIND

gallery



COVIND

**OFE/400**

20937431  
20501225

materiale | material | material PMMA - Acrylglas

peso | weight | Gewicht 5,120 Kg

applicabilità | suitable to | für VOLVO FE 2006  
VOLVO FL 2006  
VOLVO VM



**VOLVO**

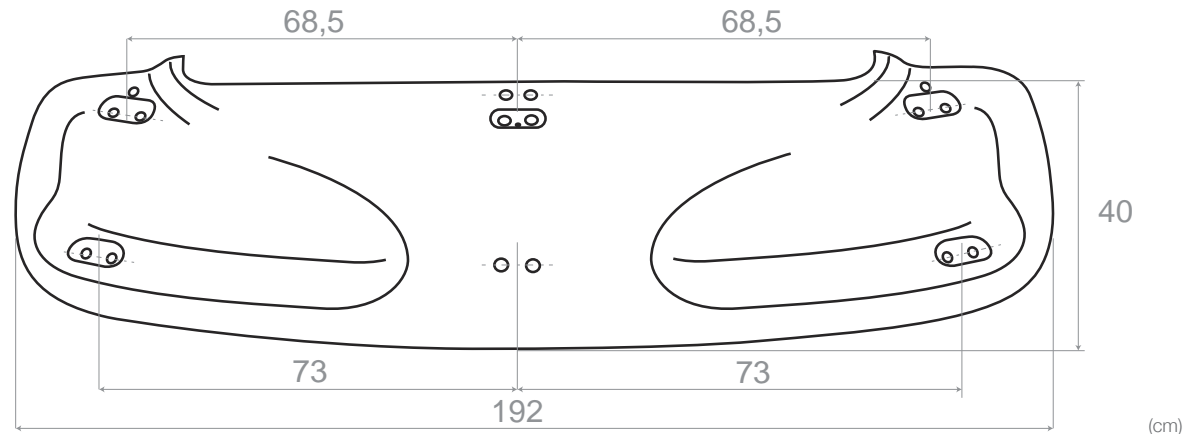

extra



# COVIND

**OFL/400** 20937442  
20743944

materiale | material | material PMMA - Acrylglas

peso | weight | Gewicht 5,315 Kg

applicabilità | suitable to | für VOLVO FE  
VOLVO FL  
VOLVO VM

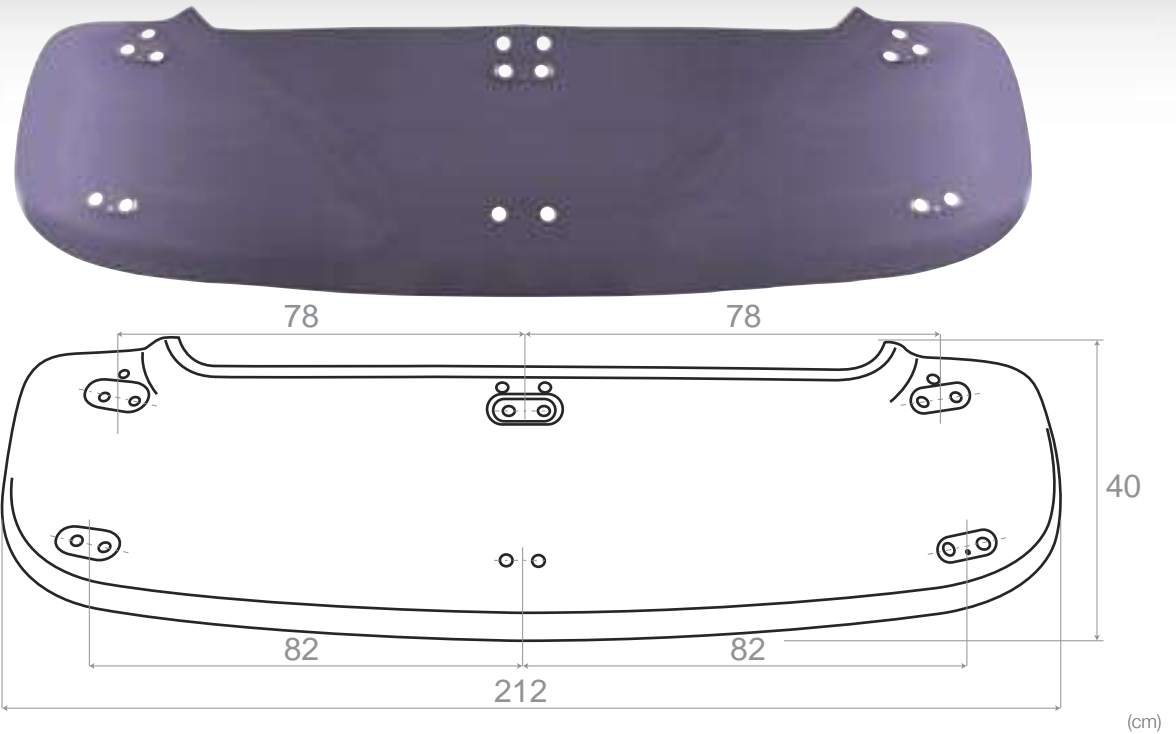

**385/480** 20819179



**2FH/400** 20456709

materiale | material | material PMMA - Acrylglas

peso | weight | Gewicht 1,920 Kg

applicabilità | suitable to | für VOLVO FH12-16 2002→2008  
VOLVO FM7-12 2002→2008

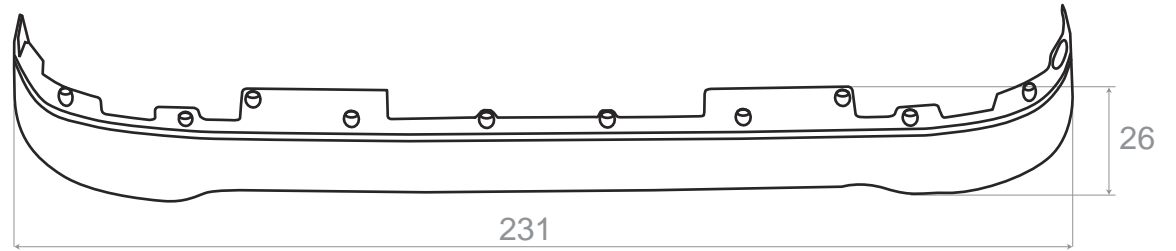

(cm)

extra



**2FH/410** 20527443



**2FH/480**

20467422  
20467412  
20467414  
20467424



**OFH/400** 8189318  
8140923

materiale | material | material PMMA - Acrylglas

peso | weight | Gewicht 2,630 Kg

applicabilità | suitable to | für VOLVO FH12-16  
VOLVO FM12

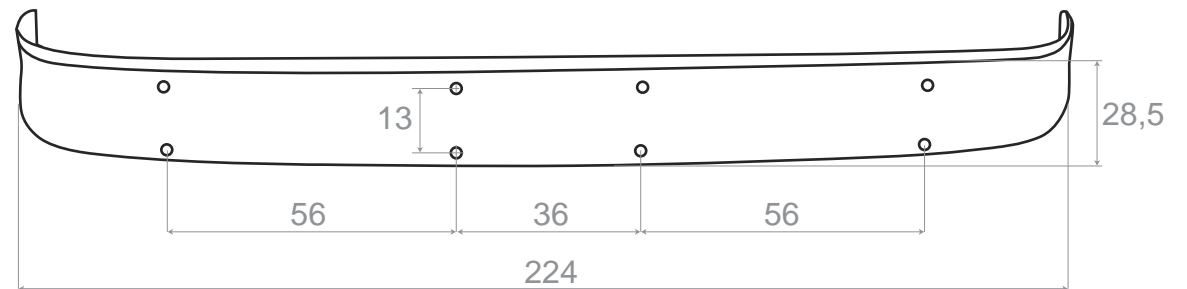

(cm)

extra



**COVINDO**

gallery



COVIND

gallery





COVIND

**COVIND SPA**

**SERVIZIO VENDITE ITALIA**  
DOMESTIC SALES DPT.

 +39 011 8965702

 +39 011 8965714

 +39 011 8965719

 +39 011 8965756

**E.MAIL** [vendite@covind.it](mailto:vendite@covind.it)

**SERVIZIO VENDITE ESTERO**  
INTERNATIONAL SALES DPT.

 +39 011 8965722

 +39 011 8965735

 +39 011 8965759

**E.MAIL** [export@covind.it](mailto:export@covind.it)



## COVIND S.P.A.

Strada della Cebrosa, 68-70-72  
10036 Settimo Torinese (TO) - ITALY

☎ +39 011 8965711

☎ +39 011 8977830

✉ [marketing@covind.it](mailto:marketing@covind.it)

[www.covind.it](http://www.covind.it)

